



SAPPRO

Pipes and Fittings



GERMAN
Technology



ENGINEERED
Piping Systems

YOUR SMART CHOICE

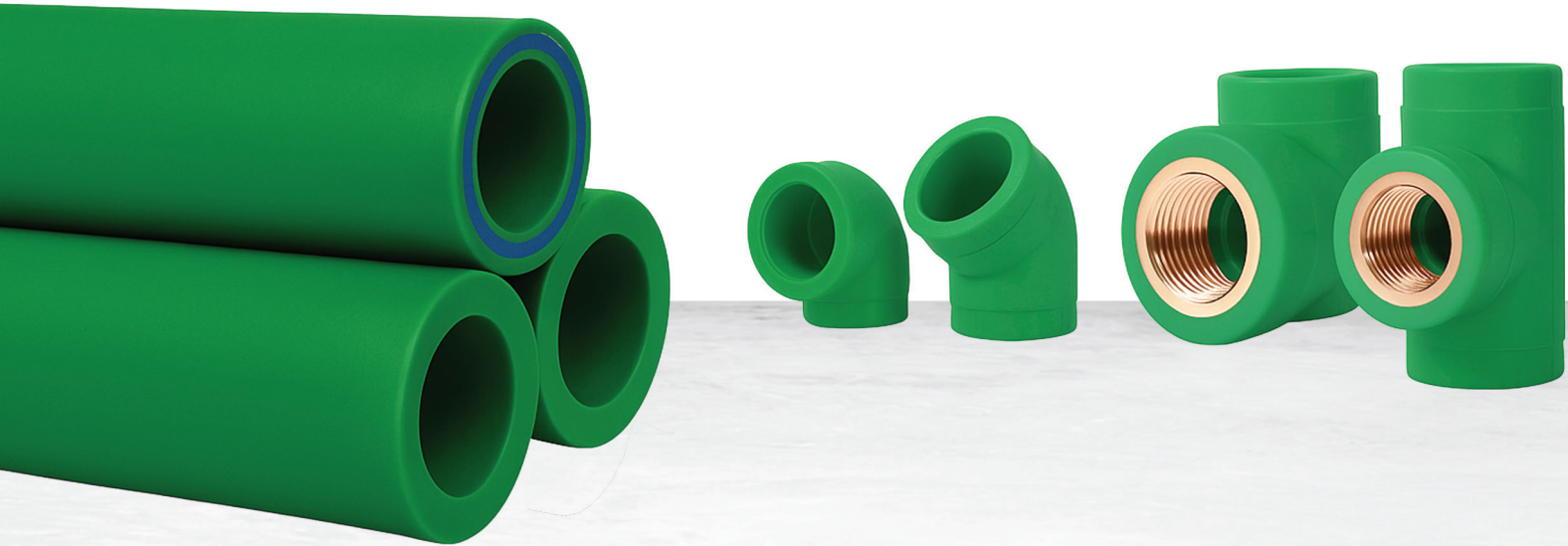

Made for you



Saudi Factory co. for plastic products
Kingdom of Saudi Arabia -Riyadh
p.o Box -225931 - Postal Code -11324



+966112469000 / +966505248483



sales@sfpp.com.sa



www.sfpp.com.sa



Contents

About Saudi Factory CO.For for Plastic .	7
A Journey of Quality and Innovation	
Our products Are Built to Last	
Our Goal: Your Satisfaction	
A Vision and Mission	9
Our Core Values	7
- Excellence	
- Partnership	
- Transparency	
- Continuous Development	
Management Responsibility and Quality Policy	11
At SAPPRO, we are committed to.	
Advantages of SAPPRO	11
Quality Control	13
1 -Hydrostatic pressure testing machine	
2 - Tensile strength and Elongation test	
3 - HEAT REVERSION TEST	
4- Impact test	
5- Measuring Dimensions	
6- Melt FLOW Rate	
7- Opacity Test	
Raw Material	17
Technical data	
PPR TECHNICAL SPECIFICATION	
Pipe Dimension and Tolerances According to DIN 8077 - SDR 7,4 (PN 16)	
PPR Pipe PN20 - SDR 6	
MULTILAYER , WITH FIBER REINFORCED 3 LAYERS	
Faser Composite Technology Fiber Glass Advantages	19
SAPPRO Pipes UV-Resistance	20
SAPPRO UV RESISTANCE PPR PIPE 2 LAYERS	
SDR 7,4 (S 3.2)	
SAPPRO UV RESISTANCE MULTILAYER, WITH FIBER REINFORCED 4 LAYERS	22
SDR 7,4 (S 3.2)	
Welding Technique	23
Distance Between Clamps in PP-R Pipe Installation	
Fiberglass Reinforced PP-R Pipes	
During the installation of the pipes from the main line	25
Test Procedure afterAssembling	26
installation and Expansion compensation	27
LINEAR EXPANSION	27
Expansion Loop	28

Stress Status	29
CHEMICAL RESISTANCE.....	30
PIPE DIMENSIONS AND TOLERANCES:	34
S 2,5 PN 20	
S 3,2 PN 16	
LIFE-TIME SPAN ACCORDING TO TEMPERATURES	35
AND PRESSURE APPLIED	
SAPPRO PIPES PRODUCTS RANGE	38
GREEN PPR PIPE 5.8M	
GREEN MULTILAYER Pipes 5.8 M ,FIBER 3LAYERS	
ANTI UV PIPE BLACK 5.8M	
ANTI UV PIPE BLACK 5.8 M 2 LAYERS	
ANTI UV MULTILAYER Pipes 5.8 M FIBER 4 LAYERS	
GREEN FITTINGS PRODUCTS RANGE	
CROSSOVER	
CROSSOVER WITH SOCKET	
SHORT CROSSOVER	
ELBOW 90°DEGREE	
ELBOW45°DEGREE	
MALE PLUG	
SOCKET	
PPR SADDLE	
EQUAL TEE	
PPR FLANGE	
STOPEND CAP	
PPR PLASTIC TRANSITION UION	
REDUCER	
REDUCED TEE	
SOCKET REDUCER	
PPR Brass Union With Copper	
FEMALE BRASS DOUBLE ELBOW	
BALL VALVE UNION	
PPR GATE VALVE	
Ball Valve	
Concealed Alloy Brass Long Valve	
Concealed Alloy Brass Valve light weight	
GATE UNION VALVE	
SIPHONE VALVE (MEDIUM/HEAVY)	
FEMALE BRASS TEE	
MALE BRASS TEE	
FEMALE BRASS SOCKET	
MALE BRASS SOCKET	
MALE HEXAGON BRASS SOCKET	
FEMALE HEXAGON BRASS SOCKET	
FEMALE BRASS ELBOW 90°	
FEMALE TRANSITION BRASS UNION	
MALE TRANSITION BRASS UNION	

UV BLACK FITTINGS PRODUCTS RANGE..... 63

- ANTI UV CROSSOVER
- ANTI UV CROSSOVER WITH SOCKET
- ANTI UV SHORT CROSSOVER
- ANTI UV ELBOW 90°DEGREE
- ANTI UV ELBOW 45°DEGREE
- ANTI UV MALE PLUG
- ANTI UV SOCKET
- ANTI UV SADDLE
- ANTI UV EQUAL TEE
- ANTI UV FLANGE
- ANTI UV STOPEND ENDCAP
- ANTI UV TRANSITIONPPR UION
- ANTI UV REDUCER
- ANTI U REDCUCED TEE
- ANTI UV SOCKET REDUCER
- ANTI UV PPR TRANSITION BRASS UNION
- ANTI UV FEMALE DOUBLE ELBOW
- ANTI UV BALL VALVE UNION
- ANTI UV PPR GATE VALVE
- ANTI UV Ball Valve
- ANTI UV CONCEALED LONG VALVE
- ANTI UV CONCEALED LIGHT WEIGHT VALVE
- ANTI UV GATE UNION VALVE
- ANTI UV SIPHONE VALVE (MEDIUM/HEAVY)
- ANTI UV FEMALE BRASS TEE
- ANTI UV MALE BRASS TEE
- ANTI UV FEMALBRASS SOCKE
- ANTI UV MALE BRASS SOCKET
- ANTI UV MALE HEX BRASS SOCKET
- ANTI UV FEMALE IHEXAGON BRASS SOCKET
- ANTI UV FEMALE BRASS ELBOW 90°
- ANTI UV MALE BRASS ELBOW 90°
- ANTI UV TRANSITION FEMALE BRASS UNION
- ANTI UV TRANSITION MALE BRASS UNION
- CONCEALED VALVE ACCESSORIES
- SIPHONE VALVE ACCESSORIES
- CONCEALED VALVE BRASS MECHANISM
- SIPHONE VALVE BRASS MECHANISM
- GATE VALVE BRASS MECHANISM
- CONCEALED VALVE EXTENSION BRASS
- PPR WELDING SOCKET
- PPR PIPE REPAIR KIT
- PPR PIPE CUTTER
- PPR PIPE PRESSURE TESTING MACHINE
- PPR SOCKET FUSION WELDING MACHINE
- PPR SOCKET FUSION WELDING MACHINE

Certificates..... 86





About Saudi Factory CO.For for Plastic

SFPP & HerTrade Mark **SAPPRO** was established at 2011 as specialized Company for potable PPR plastic pipes over KSA and middle east.It is a leading company in K.S.A and the Middle East.

We always work in accordance with the latest manufacturing techniques,German technology standards, and international standards. The company has the latest equipments and updated technologies for the production process, monitoring quality control and the flow of the production process to fully meet requirements of the market and customers.

نبذة عن مصنع السعودية للمنتجات البلاستيكية

شركة SFPP وعلامتها التجارية **سابرو** تأسست في 2011م كشركة متخصصة في زأابا بيلبلاسا PPR لكيصلصاحة للاستخدامات الصحية فذأجميع فيحاء الكلمة العربية السعودية والشرق الأوسط. وشأ في هركة ارئدة فأ في لكلمة العربية السعودية والشرق الأوسط. نعاد لمئمأ فأ فمأ لأحدث ققنننات التصنيع، ومعايير الكقنولوجوا الألمانية، والمعايير الدولية. اقمك لشركة دأدث المقعدات والققنننات المحدثة لعيلمة الاقناج، ومريقلة القة،و، وضمائسنا نأببة العيلمة الاقناجبة ليلبلة مبلطقات الوسق والعملاء بالقامل.

About Saudi Plastic Products Factory

A Journey of Quality and Innovation

The Saudi Plastic Products Factory is more than just a factory; it is a symbol of innovation and excellence in the industrial world. Established with a clear vision to provide advanced plastic solutions that meet the diverse needs of various sectors within Saudi Arabia and beyond.

We have become the trusted partner for countless companies and organizations, thanks to our commitment to global quality standards and continuous development. We utilize the latest technologies to ensure every product we deliver reflects the quality you deserve.

Our products Are Built to Last:

We don't just produce products; we build trust. Our plastic products are designed to offer high efficiency, exceptional durability, and compatibility with all requirements. Whether you're seeking solutions for infrastructure, thermal systems, or large-scale projects, we are here to deliver the very best.

Our Goal: Your Satisfaction

With a professional team and a passion for excellence, we turn every project into a sustainable success. Because we believe quality is not just a choice, but a way of life.

Made for you

Vision

To become the leaders in plastic products manufacturing across Saudi Arabia and the Middle East, achieving the highest standards of innovation and quality while building a sustainable future that supports industrial development and strengthens the Kingdom's position in global markets.

Mission

Quality First: We are committed to delivering world-class plastic products that meet our clients' aspirations and contribute to their success.

Sustainable Innovation: We continuously strive to develop advanced production technologies that combine efficiency and environmental consciousness.

Customer Satisfaction: We build long-term relationships with our clients based on trust and mutual respect.

Industrial Development: We support national growth by providing plastic solutions that cater to local and global market demands.

Social Responsibility: We promote sustainability and environmental protection by using eco-friendly materials and minimizing environmental impact.

Our Core Values

- **Excellence:** Always striving to exceed expectations and achieve the highest quality standards.
- **Partnership:** Believing in the importance of mutual collaboration to achieve shared success.
- **Transparency:** Committing to clarity and honesty in all our interactions.
- **Continuous Development:** Investing in technology and training to achieve outstanding results.

Management Responsibility and Quality Policy

AT SAPPRO, WE ARE COMMITTED TO :

- Assess the quality of raw materials, semi-finished goods and the final products during production process .
- Ensure that the whole production process operates according to the desired standards, and in case of any deviation(s), necessary corrective action would be taken.
- Suggest measures and plans to improve the standard of goods produced without much of cost escalation.
- Develop quality consciousness among the various sections for our industrial units.
- Providing products of excellent quality that are consistent with the requirement and expectations of our customers.
- Implementing and maintaining an effective quality management system.
- Starting for a right time approach to manufacture and commit an on time delivery of products.

ADVANTAGES OF **SAPPRO** PIPES

Flexibility

Features high flexibility, making it easy to install and adapt to various conditions.



01

02



Ease of Installation

Easy to install, saving time and effort during the installation process.

Mechanical Strength

Exhibits high mechanical strength, ensuring durability and long service life.



03

04



Corrosion Resistance

Resists chemical corrosion, ensuring excellent performance in harsh environments.

Impact Resistance

Designed to withstand impacts and high pressures.



05

06



Resistance to Biological Attack

Resistant to bacterial and fungal growth.

Fire Resistance

Made from fire-resistant materials to ensure safety.



07

08



Abrasion Resistance

Ensures excellent long-term performance without deterioration.

SAPPRO Pipe has well equipped technical service department having qualified engineers to provide technical advice to civil engineers, contractors, etc., about its products - UPVC and PPR and their application.

Quality Control

We have an integrated quality control laboratory supplied with the devices needed for raw materials testing, pipe inspection during manufacturing and final product testing before being delivered to our customers.

مراقبة الجودة

لدينا مختبر متكامل لمراقبة الجودة مزود بالأجهزة اللازمة لاختبار المواد الخام وفحص الأنابيب أثناء التصنيع وإجراء الاختبارات النهائية للمنتجات قبل تسليمها لعملائنا.



1 -Hydrostatic pressure testing machine

To make sure of pipe endurance to internal pressure through a device totally controlled by the computer.

It enables us to test about twelve samples at the same time at a temperature range from 20-100 C.

According to Din standards testing pressure is calculated from following equation:

$$P = \frac{2\sigma S}{D-S}$$

P @ pressure of testing

D @ the mean outside diameter

S @ the minimum wall thickness

s @ the hoop stress, that is dependent on Material type, testing period and temp.

1- جهاز اختبار الضغط الداخلي للماسورة

لضمان تحمل الأنابيب للضغط الداخلي من خلال جهاز يتم التحكم فيه بالكامل بواسطة الكمبيوتر.

يتيح لنا اختبار حوالي اثني عشر عينة في نفس الوقت في نطاق درجة حرارة من 20-100 درجة مئوية.

يتم حساب ضغط الاختبار Din وفقاً لمعايير باستخدام المعادلة التالية:

$$P = \frac{2\sigma S}{D-S}$$

ضغط الاختبار P @

D @ القطر الخارجي للماسورة

S @ اقل سمك للماسورة

الاجهاد الحلقي الدوراني، وهو يعتمد @ s على نوع المادة وفترة الاختبار ودرجة الحرارة.



2 - Tensile strength and Elongation test

We have a universal testing machine that measures the following mechanical properties of the materials:

Tensile Strength: It plots the Tensile strength of material when stress or load is applied on the sample.

Modulus of Elasticity: Measures the stiffness of the material.

Elongation at Break: Measures the extent of sample strain before it breaks.

2- اختبار قوة الشد والاستطالة

آلة اختبار الشد تقيس الخصائص الميكانيكية التالية للمواد :

قوة الشد: تحدد قوة الشد للمواد عند لإجهاد أو الحمل على العينة تطبيق

معامل المرونة: يقيس صلابة المادة

الاستطالة عند الكسر: يقيس مدى الاجهاد على العينة



3 - HEAT REVERSION TEST

It measures the change in length of pipe samples after exposure to high temperature and the ability to resist heat without showing changes in dimensions.

3- الارتداد العكسي

يقيس التغير في طول عينات الأنابيب بعد تعرضها لدرجة حرارة عالية وقدرتها على مقاومة الحرارة دون ظهور اي تغير في الابعاد.



4- Impact test

- To make sure of pipes endurance to outer loads after being installed.
- It Measures the toughness of sample and its ability to absorb applied energy.

4- اختبار التصادم

- لضمان الأنابيب للأحمال الخارجية بعد تركيبها.
- يقيس صلابة العينة وقدرتها على تحمل الاحمال الواقعة عليها .

5- Measuring Dimensions

Measure pipe dimensions by using caliber & circometer.



5- قياس الابعاد

قياس أبعاد الأنبوب عن طريق البوكليز والسيركوميتر.





6- Melt FLOW Rate

- It measure melt flow rate of ppr material and melt flow rate of pipe under certain contain condition of temperature and load.
- It gives an index of the proper condition of material production.

6- معدل تدفق الخام المنصهر

- يقوم الجهاز بقياس معدل تدفق الخام والمواسير تحت درجات حرارة معينة وحمل معين.
- هذا الاختبار يعطي مؤشر للظروف التشغيلية المناسبة للمادة الخام.



7- Opacity Test

- Its mainly used to determine the transmitted visible light through the pipe.

7- اختبار قياس العتامة

- يقوم الجهاز بقياس معدل مرور الضوء المرئي من خلال الأنابيب.

Raw Material
Technical data :

Polypropylene Random Copolymer (PP-R) Pipe and fittings are produced using PP Random Copolymer (PP-R). PP Random Copolymer is commonly used in drinking water installations, hot water, floor and radiator heating systems and every kind of industrial liquid distribution systems. PP-R has a lot of advantages over other plastics such as; long life duration, high resistance to pressure and heat, better flexibility, high acoustic and thermal insulation.

المواد الخام
البيانات الفنية :

(PP-R) بولي بروبيلين كوبوليمر يستخدم البولي بروبيلين في إنتاج المواسير والوصلات بشكل شائع في تركيبات مياه الشرب، وأنظمة المياه الساخنة، وأنظمة التدفئة الأرضية والمبردات وكل أنواع أنظمة توزيع السوائل الصناعية.

يتمتع البولي بروبيلين كوبوليمر بالعديد من المزايا مقارنة بالبلاستيك الأخرى مثل: عمر الخدمة الطويل، والمقاومة العالية للضغط والحرارة، وذا مرونة أفضل، والعزل الصوتي والحراري العالي.

PPR TECHNICAL SPECIFICATION:

Characteristics		Unit	Test Method	Values
Density	+23°C	g/cm ³	ISO 1183	0,909
Melt Flow Index (MFI)	190 °C / 5 kg	g/10 min	ISO 1133	0,4-0,6
	230°C / 2,16 kg	g/10 min	ISO 1133	0,2-0,5
	230°C / 5 kg	g/10 min	ISO 1133	0,8-1,3
Tensile Stress at yield (23°C)	(50 mm/min)	MPa	ISO 527	25
Tensile Strain at Yield	(50 mm/min)	%	ISO 527	10
Flexural Modules	+23°C	N/mm ²	ISO 527	800
Charpy Impact Strength (notched)	+23°C	kJ/m ²	ISO 179	>15
	0°C	kJ/m ²	ISO 179	>5
Charpy Impact Strength (unnotched)	0°C	kJ/m ²	ISO 179	No break
DIN 53460	130			
	(5 kg)	°C		60
Melting Range		°C	Polarizing Microscope	140-150
Linear Thermal Expansion Co-efficient		1/K	DIN 53752	1,5x10 ⁻⁴
Thermal Conductivity		W/mK	DIN 52612	0,24
Hardness (Shore D)	(3 sec value)		ISO 868	65
Pipe Friction Factor				0,007

Pipe Dimension and Tolerances According to DIN 8077 - SDR 7,4 (PN 16) :



Outside Ø mm.	Tolerance mm.	Thickness mm.	Tolerance mm.	Inside Ø mm.	In" inches
20	+0.3/-0	2.8	+0.4/-0	14.00	1/2"
25	+0.3/-0	3.5	+0.5/-0	18.00	3/4"
32	+0.3/-0	4.4	+0.6/-0	23.20	1"
40	+0.4/-0	5.5	+0.7/-0	29.00	1 1/4"
50	+0.5/-0	6.9	+0.8/-0	36.20	1 1/2"
63	+0.6/-0	8.6	+1.0/-0	45.80	2"
75	+0.7/-0	10.3	+1.2/-0	54.40	2 1/2"
90	+0.9/-0	12.3	+1.4/-0	65.40	3"
110	+1.0/-0	15.1	+1.7/-0	79.80	4"
110	+1.0/-0	15.1	+1.7/-0	79.80	4"

PPR Pipe PN20 - SDR 6

Polypropylene (PPR) pipes are long-span life pipes. produced by non-corrosive structure and non-toxic materials, they are widely used in the safe hot and cold potable water supply.

أنابيب بولي بروبيلين ضغط 20 بار

أنابيب البولي بروبيلين (بي بي ار) هي أنابيب مصممة للإستخدام طويل الأمد. بفضل مزيجهما الغير قابل للتآكل والمواد المستخدمة الغير السامة ، فهي تستخدم على نطاق واسع في إمدادات مياه الشرب الساخنة والباردة.

Outside Ø mm.	Tolerance mm.	Thickness mm.	Tolerance mm.	Inside Ø mm.	In" inches
20	+0.3/-0	3.4	+0.5/-0	13.20	1/2"
25	+0.3/-0	4.2	+0.6/-0	16.60	3/4"
32	+0.3/-0	5.4	+0.7/-0	21.20	1"
40	+0.4/-0	6.7	+0.8/-0	26.60	1 1/4"
50	+0.5/-0	8.3	+1.0/-0	33.40	1 1/2"
63	+0.6/-0	10.5	+1.2/-0	42.00	2"
75	+0.7/-0	12.5	+1.4/-0	50.00	2 1/2"
90	+0.9/-0	15.0	+1.7/-0	60.00	3"
110	+1.0/-0	18.3	+2.0/-0	73.40	4"

MULTILAYER , WITH FIBER REINFORCED 3 LAYERS
متعدد الطبقات، مدعم بالألياف الفايبر 3 طبقات

SDR -7,4 -(S 3.2) :

Outside Ø mm.	Tolerance mm.	Thickness mm.	Tolerance mm.	Inside Ø mm.	In" inches
20	+0.3/-0	2.8	+0.4/-0	14.00	1/2"
25	+0.3/-0	3.5	+0.5/-0	18.00	3/4"
32	+0.3/-0	4.4	+0.6/-0	23.20	1"
40	+0.4/-0	5.5	+0.7/-0	29.00	1 1/4"
50	+0.5/-0	6.9	+0.8/-0	36.20	1 1/2"
63	+0.6/-0	8.6	+1.0/-0	45.80	2"
75	+0.7/-0	10.3	+1.2/-0	54.40	2 1/2"
90	+0.9/-0	12.3	+1.4/-0	65.40	3"
110	+1.0/-0	15.1	+1.7/-0	79.80	4"

Faser Composite Technology Fiber Glass Advantages :

The composite pipes made in the multi-layer extrusion process produce a higher stability due to the fibre filling in the middle layer, Compared to customary PP-pipes there are further advantages:

- Reduced expansion Compared to customary PP - Pipes.
- Higher flow rate due to increased inner diameter.
- Greater support spacings.
- Less weight and high hardness.
- Capable of withstanding high temperatures liquids .

مميزات مواسير سابرو المسلحة بالفايبر جلاس:

تنتج الأنابيب متعددة الطبقات بعملية السحب منتجة مواسير ذات ثبات عالي لاحتوائها على طبقة داخلية من الفايبر جلاس مقارنة بالمواسير البولي بروبيلين التقليدية ولها مميزات أخرى:

- تقليل معدل التمدد الحراري مقارنة بالمواسير البولي بروبيلين العادية
- معدلات تمدد عالية للسوائل نتيجة كبر القطر الداخلي.
- تقليل عدد القفزات المستخدمة لتثبيت المواسير.
- وزن أقل وصلابة عالية.
- القدرة على تحمل درجات حرارة عالية أعلى من مواسير البولي بروبيلين التقليدية.

SAPPRO Pipes UV-Resistance :

PP-R UV PIPES ARE MANUFACTURED WITH ADDITIONAL UV PROTECTION.

Main Advantages

Odourless and hygienic

These pipes are most ideal for carrying drinking water as they do not **subject** to contamination.

Protected against UV rays

The UV protected layer is comprised of UV resistant materials which protect the pipe from flaking when exposed to sunlight over time.

High chemical resistance

Pipes offer excellent resistance to acids, oxidizing agents, alkalis, oils and domestic effluents.

Smooth bore

Pipes have a smooth inside surface and hence better flow characteristics.

Longer lasting Pipes have a smooth inside surface and hence better flow characteristics.

As these pipes are free from weaknesses caused by scale formation, rusting, weathering and chemical action they last or a lifetime.

مواسير سابرو المقاومة للأشعة فوق البنفسجية

المزايا الرئيسية:

عديمة الرائحة وصحية

تعتبر هذه الأنابيب مثالية لنقل مياه الشرب لأنها لا تتعرض للتلوث.

محمية ضد الأشعة فوق البنفسجية

تتكون الطبقة المحمية من الأشعة فوق البنفسجية من مواد مقاومة للأشعة فوق البنفسجية والتي تحمي الأنبوب من التقشر عند تعرضه لأشعة الشمس مع مرور الوقت.

ذات مقاومة كيميائية عالية

توفر الأنابيب مقاومة ممتازة للأحماض والعوامل المؤكسدة والقلويات والزيوت والنفائيات السائلة المنزلية.

تتمتع الأنابيب بسطح داخلي أملس وبالتالي خصائص تدفق أفضل.

وبما أن هذه الأنابيب خالية من نقاط الضعف الناجمة عن تكون القشور والصدأ والعوامل الجوية والتأثيرات الكيميائية، فإنها تدوم سنوات عديدة.

SAPPRO UV RESISTANCE PPR PIPE 2 LAYERS

أنابيب لمقاومة الأشعة فوق البنفسجية بطبقتين من سابرو



SDR 7,4 (S 3.2) :

مدة التشغيل وفقاً لمعيار

Outside Ø mm.	Tolerance mm.	Thickness mm.	Tolerance mm.	Inside Ø mm.	In" inches
20	+0.3/-0	2.8	+0.4/-0	14.00	1/2"
25	+0.3/-0	3.5	+0.5/-0	18.00	3/4"
32	+0.3/-0	4.4	+0.6/-0	23.20	1"
40	+0.4/-0	5.5	+0.7/-0	29.00	1 1/4"
50	+0.5/-0	6.9	+0.8/-0	36.20	1 1/2"
63	+0.6/-0	8.6	+1.0/-0	45.80	2"
75	+0.7/-0	10.3	+1.2/-0	54.40	2 1/2"
90	+0.9/-0	12.3	+1.4/-0	65.40	3"
110	+1.0/-0	15.1	+1.7/-0	79.80	4"

SAPPRO UV RESISTANCE MULTILAYER, WITH FIBER REINFORCED 4 LAYERS

سابرو متعدد الطبقات مدعم بالفايبر 4 طبقات لمقاومة الأشعة فوق البنفسجية

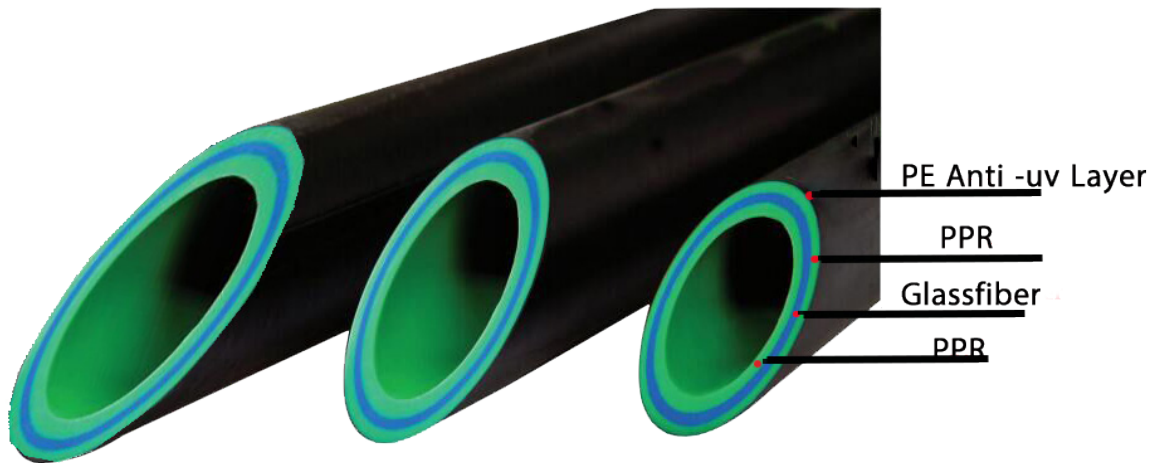

SDR 7,4 (S 3.2) :

Outside Ø mm.	Tolerance mm.	Thickness mm.	Tolerance mm.	Inside Ø mm.	In" inches
20	+0.3/-0	2.8	+0.4/-0	14.00	1/2"
25	+0.3/-0	3.5	+0.5/-0	18.00	3/4"
32	+0.3/-0	4.4	+0.6/-0	23.20	1"
40	+0.4/-0	5.5	+0.7/-0	29.00	1 1/4"
50	+0.5/-0	6.9	+0.8/-0	36.20	1 1/2"
63	+0.6/-0	8.6	+1.0/-0	45.80	2"
75	+0.7/-0	10.3	+1.2/-0	54.40	2 1/2"
90	+0.9/-0	12.3	+1.4/-0	65.40	3"
110	+1.0/-0	15.1	+1.7/-0	79.80	4"

Welding Technique

The quality of an installation depends on the tightness, stability and lifetime of its connections. Fusion welding technique is safe because parts made of polypropylene create a homogenous connection within the process. When the welded joint cools down, it can be fully loaded. The resulting joints are very reliable, and they are as strong as the pipe itself. The pipe may even break before the socket welded joint under tension.

Welding takes only a few seconds. After cutting the pipe perpendicularly to its axis, both the pipes and the fittings (these must be clean if not please clean it with a cloth or alcohol- water solution) are heated with the welding machine (generally up to 260 °C +/- 10 °C) and they are joined without twisting.

For proper connections please follow the table given below :

تقنية اللحام

تعتمد جودة التركيب على إحكام وثبات وصلات الأنابيب وعمرها الافتراضي. تعتبر تقنية اللحام بالانصهار آمنة لأن الأجزاء المصنوعة من مادة البولي بروبيلين تشكل اتصالاً متجانساً خلال عملية اللحام. عندما يبرد اللحام، يمكن تحميله بشكل كامل. وتكون الوصلات الناتجة موثوقة للغاية، وتكون قوية مثل الأنابيب نفسه. قد يتعرض الأنبوب للكسر قبل أن يتعرض الوصل لعملية اللحام تستغرق بضع ثوانٍ فقط. بعد قطع الأنبوب بشكل عمودي على محوره، (يجب أن تكون نظيفة، وإذا لم تكن نظيفة، يرجى تنظيفها بقطعة قماش أو محلول كحول-ماء) يتم تسخين كل من الأنابيب والتركيبات باستخدام ماكينة اللحام (عادةً تصل درجة الحرارة إلى 260 درجة مئوية +/- 10 درجات مئوية) ويتم توصيلها بدون تدوير.

للحصول على لحام جيد ، يرجى اتباع الجدول الموجود أدناه :



Outer Diameter (mm)	Heating Time (Secs)	Joining Time (Secs)	Cooling Time (Minutes)	Welding Depth (mm)
20	5	4	2	14,5
25	7	4	3	16
32	8	6	4	18
40	12	6	4	20,5
50	18	6	5	23,5
63	24	8	6	27,5
75	30	8	8	31
90	40	8	8	35,5
110	50	10	8	41,5
125	60	10	8	46,5

Distance Between Clamps in PP-R Pipe Installation

مسافات تثبيت القفزان لتثبيت مواسير البولي بروبيلين

Solid PP-R Pipes

TEMPERATURE DIFFERENCE ΔT (°C)	STANDARD PP-R PIPE DIAMETER (MM)									
	20	25	32	40	50	63	75	90	110	125
0	85	105	125	140	165	190	205	220	250	265
20	60	75	90	100	120	140	150	160	180	240
30	60	75	90	100	120	140	150	160	180	240
40	60	70	80	90	110	130	140	150	170	225
50	60	70	80	90	110	140	140	150	170	210
60	55	65	75	85	100	115	125	140	160	200
70	50	60	75	80	95	105	115	125	140	190

Fiberglass Reinforced PP-R Pipes

مسافات تثبيت القفزان لتثبيت مواسير الفايبر جلاس المسلحة

TEMPERATURE DIFFERENCE ΔT (°C)	STANDARD PP-R PIPE DIAMETER (MM)									
	20	25	32	40	50	63	75	90	110	125
0	115	130	150	165	185	215	240	260	280	295
20	90	100	115	130	145	165	185	200	215	225
30	90	100	115	130	145	165	185	200	210	220
40	80	90	105	120	135	155	175	190	200	210
50	80	90	105	120	135	155	175	190	180	190
60	70	80	100	115	130	145	165	180	175	180
70	65	75	90	105	120	135	155	175	175	180

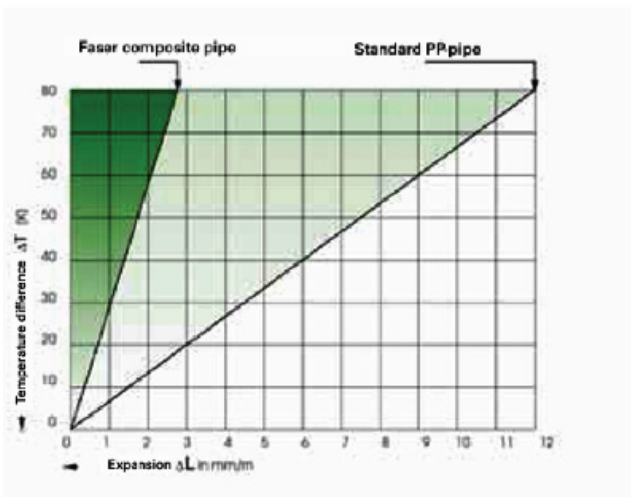

Support spacings PP-pipe and faser composite-pipe

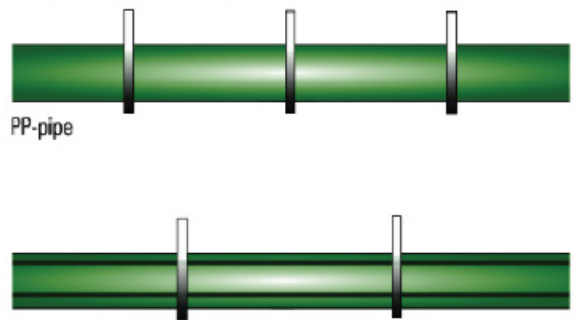

Faser composite pipe approx. 30 % more fixing distance

During the installation of the pipes from the main line to the apartments in a building one of the following techniques is used to allow the pipes to expand linearly.

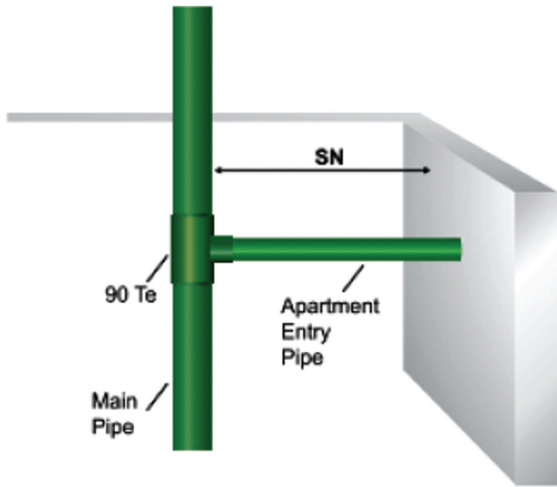

1) When a branch is embedded in concrete, as shown as in Figure the SN distance between the tee and wall opening should be ensured to allow for expansion of the pipe during change of temperature.

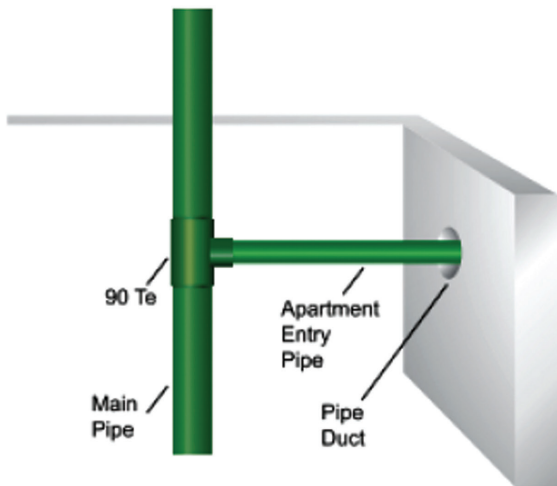

2) The hole diameter inside the wall should be bigger than the pipe diameter which passes through the wall as shown in Figure The diameter of the hole must be specified in such a manner that the branch is able to move during expansion of the main pipe.

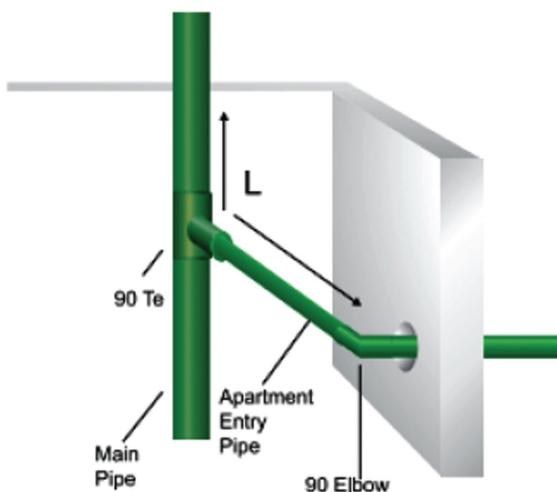

3) The L-shaped pipe segment in Figure is used to compensate for length variations due to thermal expansion.

* The horizontal spacing of fixed clamps depends on the size and type of pipe (see page 17).

Test Procedure after Assembling:

Procedure system should be checked please see the steps below.

- Whole valves in the system must be turned off.
- While filling the system, first main valve is opened slightly.
- In order to avoid strong pressure impacts, pipe lines must be reduced air pressure from the utilization points at the highest and farthest sections.
- Separate tests are made by opening the valves of every zone.

When finishing the assembly of the installation, quality control of the system must be made by following below

Test procedure:

Pressure testing shall be carried out in two stages.

1. For the first stage, a test pressure equal to the permissible working pressure plus 5 bar shall be produced twice within 30 minutes at 10 minute intervals. Then it shall be checked whether, over a further period of 30 minutes, the pressure has dropped by more than 0,6 bar and leakage has occurred.
2. The second stage shall follow the first stage without interval and shall last 2 hours. Then, it shall be checked whether the pressure has dropped by more than 0.2 bar and the pipework shows any signs of leakage.

Finally, If pressure drops more than the values given above in the manometer where test is observed, then leakage occurs. Leaking pipe line must be controlled and replaced or re-tightened.



إجراءات اختبار ما بعد التركيب:

بعد التجميع، يجب التحقق من النظام لبدء إجراءات الاختبار وفقاً للخطوات التالية:

يجب إغلاق جميع المحابس في النظام.
أثناء ملء النظام، يجب فتح المحبس الرئيسي بشكل طفيف أولاً.
لتجنب تأثيرات الضغط القوية، يجب تخفيض ضغط الهواء في خطوط الأنابيب من النقاط العليا والأبعد في النظام يتم إجراء اختبارات منفصلة عن طريق فتح محابس كل منطقة.
عند الانتهاء من تركيب النظام، يجب إجراء فحص الجودة باتباع إجراءات الاختبار التالية:
اختبار الضغط

يتم إجراء اختبار الضغط على مرحلتين:

- 1 - في المرحلة الأولى، يتم إنتاج ضغط اختبار يساوي الضغط العامل المسموح به زائد 5 بار مرتين خلال 30 دقيقة على فترات 10 دقائق. ثم يتم التحقق مما إذا كان الضغط قد انخفض بأكثر من 0.6 بار خلال فترة 30 دقيقة أخرى، وإذا حدث أي تسرب.
- 2 - يجب أن تتبع المرحلة الثانية مباشرة المرحلة الأولى دون أي توقف وتستمر لمدة ساعتين. بعد ذلك، يتم التحقق مما إذا كان الضغط قد انخفض بأكثر من 0.2 بار وما إذا كانت هناك أي علامات على تسرب في الأنابيب.

أخيراً، إذا انخفض الضغط أكثر من القيم المحددة أعلاه في المانومتر حيث يتم مراقبة الاختبار، فهذا يعني حدوث تسرب. يجب فحص خط الأنابيب المتسرب واستبداله أو إعادة إحكام غلقه .

Installation and Expansion Compensation :

Pipes can be installed under or above the floor. The installation is very easy and quick. However, one has to pay attention to the following simple points when installing polypropylene pipes. Pipes have to discharge the radial and axial extensions; compensation may be done by using Omega and U parts. As an alternative, metal compensation also can be used instead of the U parts

التركيب وتعويض التمدد:

يمكن تركيب الأنابيب تحت أو فوق الأرضية. عملية التركيب سهلة وسريعة للغاية. ومع ذلك، يجب الانتباه إلى النقاط البسيطة التالية عند تركيب أنابيب البولي بروبيلين:

يجب أن يتم تفريغ التمددات الشعاعية والمحورية للأنابيب. يمكن التعويض عن هذه التمددات باستخدام أجزاء "أوميغا" و "و كبدل، يمكن استخدام التعويض المعدني بدلاً من أجزاء "حرف U"

LINEAR EXPANSION

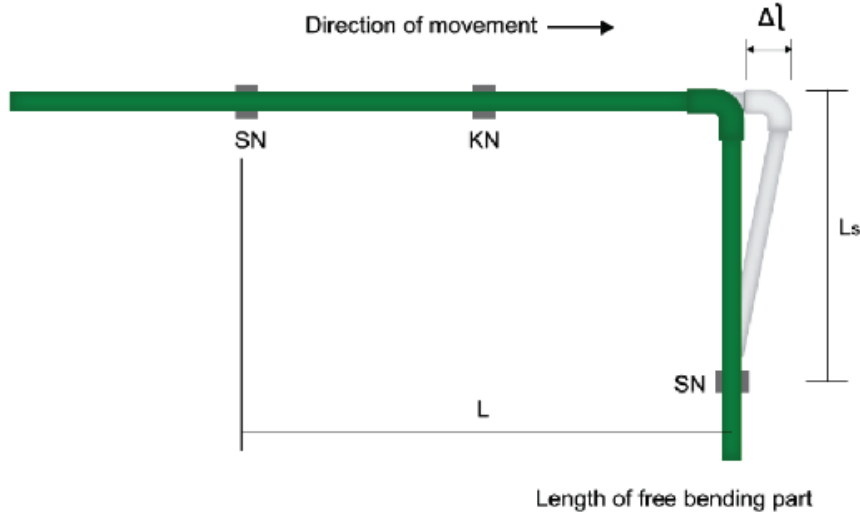

The expansion adjustments are made mostly unidirectionally in polypropylene pipes. The pipe should move freely in the axial direction.

Freely moving expansion parts are created in order to prevent the installation from linear expansion which may arise in the pipes due to temperature fluctuation.

Length of freely moving part is calculated by the following formula:

$$L_s = K \times \Delta f \times L$$

SN: Fixed point

KN: Varying point

Ls: Length of freely moving part (mm)

D: Pipe outer diameter

Δ f: Amount of elongation (mm)

L: Pipe length (m)

K: Specific constant of material (K=30)

Expansion Loop

Bending parts should be used in installations where the expansion will be bidirectional and in runs exceeding 5 meters in length.

Expansion loops cannot be removed for direction change, an expansion chamber must be designed. Shape of this expansion loop is given below.

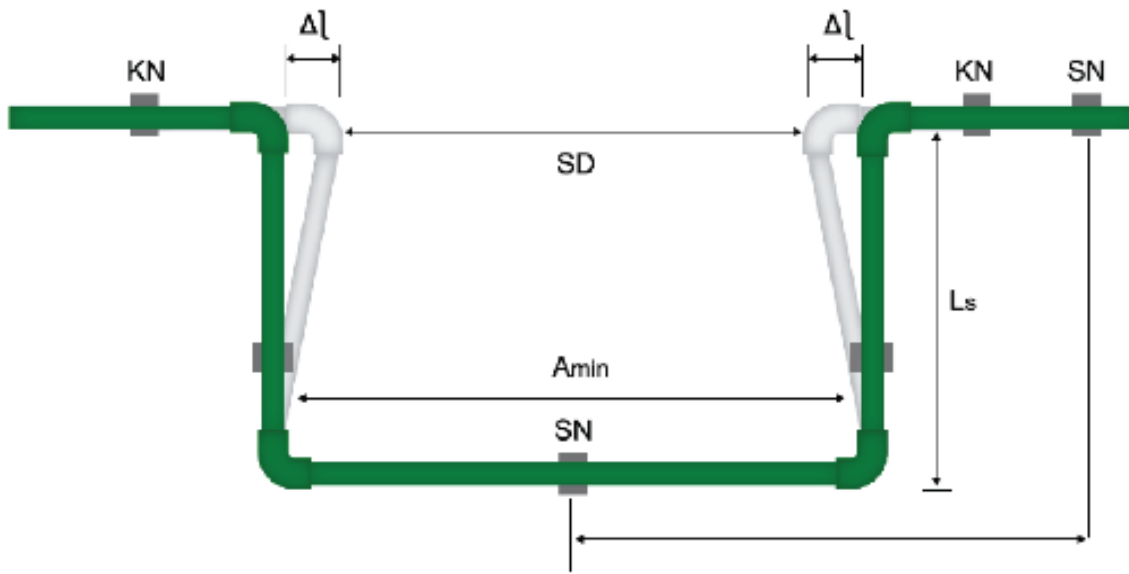

Calculation of minimum width of expansion chamber:

If the linear expansion cannot be compensated for by a change in direction, it may be necessary to install an expansion loop.

The pipe bend A_{min} is calculated according to the following formula:

Safety margin of 150mm is provided considering that elongation amount may increase under temperature fluctuation.

Length of freely moving part is calculated by the following formula:

$$A_{min} = 2 \times \Delta f \times SD$$

A_{min} : Minimum width of expansion loop

SD: Safety margin (150mm)

Ls: Length of freely moving part (mm)

D: Pipe outer diameter

Δf : Amount of elongation (mm)

L: Pipe length (m)

K: Specific constant of material (K=30)

Stress Status

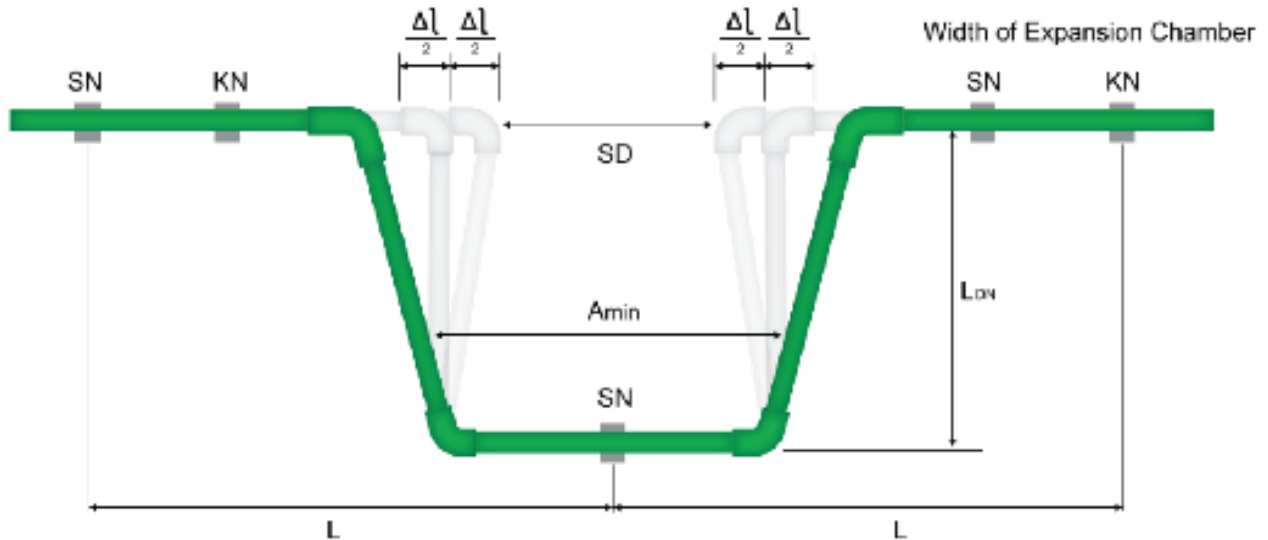

Stress status during installation, if planned and carried out properly, offers a visually perfect installation, as the linear expansion is not noticeable in the operating system. The side length LDN is calculated according to the following calculation example:

$$LDN = K \times \sqrt{D \times \Delta f / 2}$$

Amin: Minimum width of expansion loop

SD: Safety margin (150mm)

LDN: Length of stress status (mm)

D: Pipe outer diameter

Δ f: Amount of elongation (mm)

L: Pipe length (m)

K: Specific constant of material (K=30)

CHEMICAL RESISTANCE

مقاومة المواد الكيميائية

Polypropylene is a polymer with very high chemical resistance. Chemical resistance varies on factors such as composition, quality condition, time of affection, concentration and temperature. The tables shown below give chemical resistance in different temperature and concentrations.

PRODUCTS	CONCENTRATION	TEMPERATURE		
	%	20 C°	60 C°	100 C°
ACCUMULATOR ACID		F	F	
ACETIC GLACIAL ACID	100	F	P	N
ACETIC ACID	50	F	F	
ACETIC ACID	10	F	F	
ACETIC ANHYDRIDE	100	F		
ACETONE	100	F	P	N
ACRYLONITRILE	100	P		
ALUM	ALL	F	F	
AMMONIA	HIGH	F	F	
AMMONIA	10	F	F	
AMMONIA	100	F	F	
AMMONIUM ACETATE	ALL	F	F	F
AMMONIUM CARBONATE	ALL	F	F	
AMMONIUM CHLORIDE	ALL	F	F	F
AMMONIUM NITRATE	ALL	F	F	F
AMMONIUM METAPHOSPHATE	S	P	P	P
AMMONIUM PHOSPHATE	ALL	F	F	F
AMMONIUM SULPHATE	S	P	P	P
AMMONIUM BICARBONATE	S	P	P	
ANIMAL COOKING OIL		F	P	
ANTI-FRREZE CAR		F	F	
AQUA REGIA		F	N	
BARRIUM CHLORIDE	ALL	F	F	F
BEER		F		
BENZALDHEHYDE		F	F	
BENZALDHEHYDE	S	F	F	F
BENZENE		P	N	
BENZOIC ACID	S	F	F	P
BENZOYL CHLORIDE	100	N		
BITTER ALMONDS FRAGRANCE		F		

PRODUCTS	CONCENTRATION	TEMPERATURE		
	%	20 C°	60 C°	100 C°
BLEACH	12.50%			
BORAX				
BORIC ACID				
BROMINE	100	N		
BROMINE			N	
BROMINE	LOW	N	N	
BUTANE				
BUTANE (P)	100	F	F	
BUTTER		F	F	
BUTYOL ALCOHOL	100	F	F	
CALCIUM NITRATE	S	F	F	
CAMPHOR		F		
CARVON TETRAChLORIDE	100	P	N	
CHLORINE	100	N		
CHLORINE (DRY)	100	N	N	N
CHLORINE (WET)	10	P	N	N
CHLOROSULPHONIC	100	N	N	
CHROMIC ACID	S	F	N	
CHROOMIUM (3) SALTS				
CHROOMIUM (6) SALTS				
CITRIC ACID	S	F	F	F
COCOA		F	F	P
COD LIVER OIL		F		
CRESOL	100	F	P	
CRESOL	S	F	P	
CRESOL OIL		F		
CYCLOHEXANE	100	F		
CYCLOEXANOL	100	F	P	
CYCLOEXANON	100	F	N	
DECAHYDRONAPHTLENE	100	P	N	N
DIOXAN	100	F	P	N
DISTILLED WATER	100	F	F	N
ENGINE OIL		F	P	
ETHYL ALCOHOL	100	F		
ETHYL ALCOHOL	96	F	F	
ETHYL ALCOHOL	50	F	F	
ETHERS	100	F	P	
ETHYL ALCOHOL (DENATURED)	10	F	F	
ETHYL CLORIDES	100	N		

PRODUCTS	CONCENTRATION	TEMPERATURE		
	%	20 C°	60 C°	100 C°
ETHYLENE TETRAFLORIDE	100	P	N	
FORMALDEHYDE	40	F	F	
FORMALDEHYDE	30	F	F	
FORMALDEHYDE	10	F	F	
FORMIC ACID	98	F	P	
FORMIC ACID	90	F		
FORMIC ACID	50	F	F	
FORMIC ACID	10	F	F	F
FRUIT-JUICE		F	F	
FUMIC SULFURIC ACID		N	N	N
GALVANIC SOLUTIONS		F	F	
GLYCEROL	100	F	F	
GLYCEROL	HIGH	F	F	
GLYCEROL	LOW	F	F	F
GLYCOL	100	F	F	
GLYCOL	HIGH	F	F	
GLYCOL	LOW	F	F	F
PHENYLAMINE		F	P	
PHENYLMETHYLKETONE	100	P	P	
PHOSPHORIC ACID	S	F	P	
PHOSPHORIC ACID	50	F	F	
PHOSPHORIC ACID	10	F	F	F
POTASSIUM CARBONATE	S	F	F	
POTASSIUM CHLORATE	S	F	F	
POTASSIUM CHLORIDE X	S	F	F	F
POTASSIUM DICHROMATE	S	F	F	F
POTASSIUM HYDROXIDE	50	F	F	
POTASSIUM HYDROXIDE	25	F	F	
POTASSIUM HYDROXIDE	10	F	F	
POTASSIUM HYPOCHLORITE	5	F		
POTASSIUM IODIDE	S	F	F	
POTASSIUM NITRATE	S	F	F	
SEA WATER		F	F	F
SHAMPOO		F	F	
SILICONE OIL		F	P	
SOAP SOLUTION	S	F	F	
SOAP SOLUTION	10	F	F	F
SODIUM BICARBONATE	S	F	F	F
POTASSIUM SULPHATE	S	F	F	F
PROPANE®	100	F	F	F

PRODUCTS	CONCENTRATION	TEMPERATURE		
	%	20 C°	60 C°	100 C°
PROPANE	100	F	F	F
PYRIDINE	100	F	P	
SODIUM CARBONATE	S	F	F	
SODIUM CARBONATE	10	F	F	F
SODIUM CHLORATE	5	F		
SODIUM CHLORITE	25	F	F	
SODIUM CHLORIDE	S	F	F	F
SODIUM DISULPHITE	S	F	F	F
SODIUM HIDROXIDE	100	F	F	
SODIUM HYDROXIDE	50	F	F	
SODIUM HYDROXIDE	25	F	F	
SODIUM HIDROXIDE	10	F	F	
SODIUM NITRATE	S	F	F	
SODIUM NITRITE (P)	S	F		
SODIUM PERBORATE	S	F	F	F
SODIUM PHOSPHATE	S	F	F	F
QQ]O=[IO==OP[[100	F	P	
HEXAN	100	F	P	
HONEY		F	F	
HYDROBROMIC ACID	10	F	F	
HYDROFLUORIC ACID	40	F	F	
HYDROGEN PEROXIDE WATER	30	F	P	
HYDROBROMIC ACID	HIGH	F	F	
HYDROGEN PEROXIDE WATER	10	F	F	
HYDROGEN PEROXIDE WATER	3	F	F	F
INK		F	F	
ISOCTANE	100	F	P	
LACTIC ACID	90	F	F	
LACTIC ACID	50	F	F	
LACTIC ACID	10	F	F	F
LACUAL WATER	100	F	F	F
LIMESTONE		F	F	F
LINSEED OIL		F	F	
MERCURY		F	F	
MERCURY SALTS	100			
METHYL ALCOHOL	50	F	F	
METHYL ALCOHOL	100	F	F	
METHYL CHLORIDE	100	P		
METHYM ETHYL KETONE	100	F	P	
METHYLENE DIFORMAMMYDE		F		

PRODUCTS	CONCENTRATION	TEMPERATURE		
	%	20 C°	60 C°	100 C°
MILK		F	F	P
MINERAL WATER		F	F	F
NAPHTHA		F	P	
NAPHTHALENE	100	F		
NITRO BENZENE	100	P	P	
NORMAL GASOLINE		P	N	
OIL		N	N	
OLEIC ACID	100	F		
OLIVE OIL		F	F	
NITRIC ACID	50	P	N	
NITRIC ACID	25	F	F	
NITRIC ACID	10	F	F	
OXALIC ACID	S	F	F	F
OZONE	<0.5 PPM	P	P	
PARAFFINE	100	F	F	N
PETROLEUM	100	F	P	

PIPE DIMENSIONS AND TOLERANCES

اقطار وسماكات الانابيب والسماقيات

الأبعاد والتسامحات S 2,5 PN 20

Outside Ø mm.	Tolerance mm.	Thickness mm.	Tolerance mm.	Inside Ø mm.	In" inches
20	+0,3/-0	3,4	+0,5/-0	13,20	1/2"
25	+0,3/-0	4,2	+0,6/-0	16,60	3/4"
32	+0,3/-0	5,4	+0,7/-0	21,20	1"
40	+0,4/-0	6,7	+0,8/-0	26,60	1 1/4"
50	+0,5/-0	8,3	+1,0/-0	33,40	1 1/2"
63	+0,6/-0	10,5	+1,2/-0	42,00	2"
75	+0,7/-0	12,5	+1,4/-0	50,00	2 1/2"
90	+0,9/-0	15,0	+1,7/-0	60,00	3"
110	+1,0/-0	18,3	+2,0/-0	73,40	4"
125	+1,2/-0	20,8	+2,2/-0	83,40	5"
160	+1,5/-0	26,6	+2,8/-0	106,80	6"

S 3,2 PN 16

Outside Ø mm.	Tolerance mm.	Thickness mm.	Tolerance mm.	Inside Ø mm.	In" inches
20	+0,3/-0	2,8	+0,4/-0	14,00	1/2"
25	+0,3/-0	3,5	+0,5/-0	18,00	3/4"
32	+0,3/-0	4,4	+0,6/-0	23,20	1"
40	+0,4/-0	5,5	+0,7/-0	29,00	1 1/4"
50	+0,5/-0	6,9	+0,8/-0	36,20	1 1/2"
63	+0,6/-0	8,6	+1,0/-0	45,80	2"
75	+0,7/-0	10,3	+1,2/-0	54,40	2 1/2"
90	+0,9/-0	12,3	+1,4/-0	65,40	3"
110	+1,0/-0	15,1	+1,7/-0	79,80	4"
125	+1,2/-0	17,1	+1,9/-0	90,80	5"
160	+1,5/-0	21,9	+2,3/-0	116,20	6"

LONG TERM BEHAVIOR FOR SAPPRO PPR PIPES

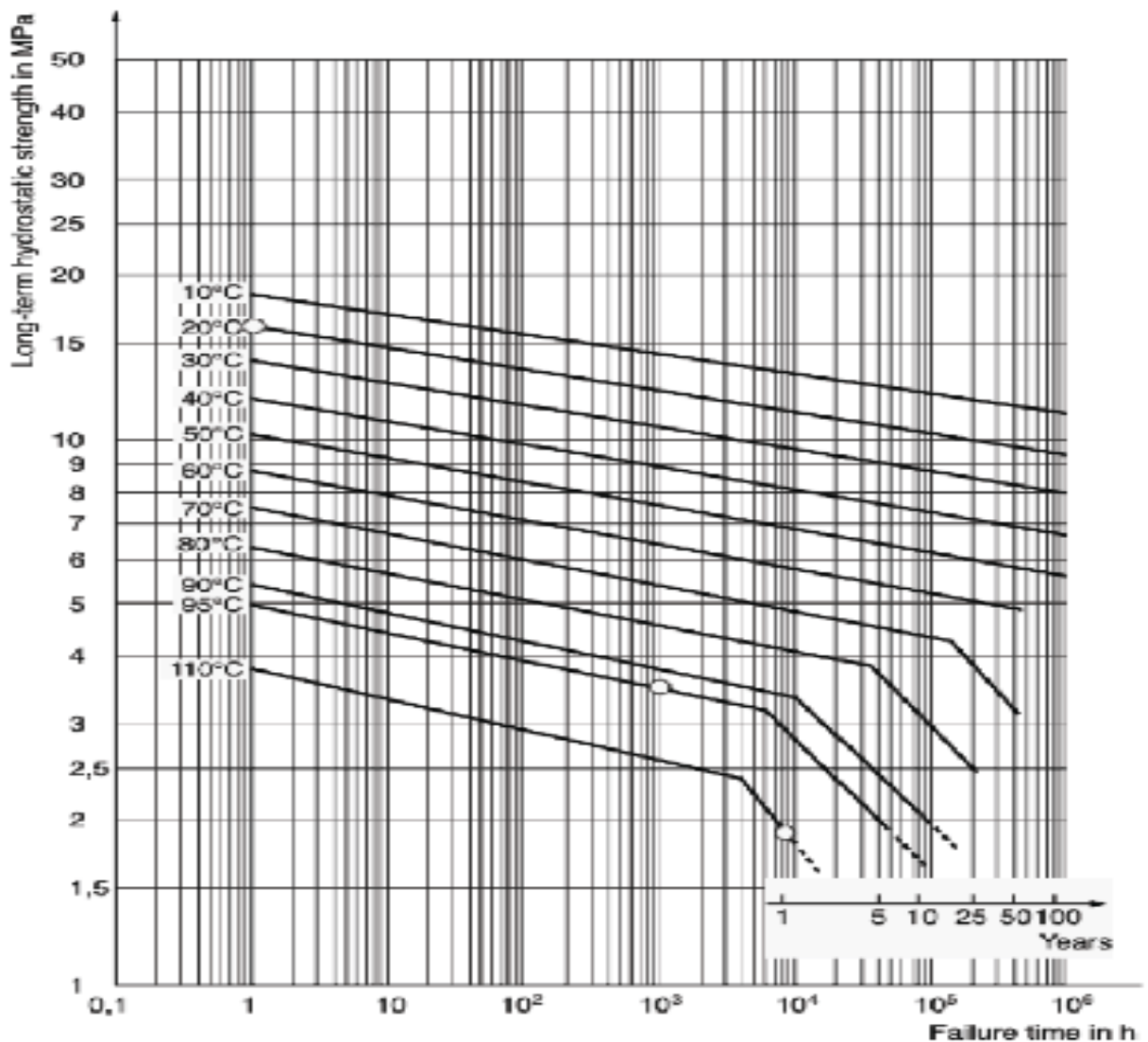

LIFE-TIME SPAN ACCORDING TO TEMPERATURES AND PRESSURE APPLIED

العمر الافتراضي وفقاً لدرجات الحرارة ومعدلات الضغط.

TEMPERATURE (C°)	YEARS OF SERVICE	PIPE SERIES (S)			
		5	4	3,2	2.5
		Standard Dimension Ratio (SDR)			
		11	9	7,4	6
		ALLOWABLE OPERATING PRESSURE (BAR)			
10	1	19,0	24,0	30,2	38,0
	5	18,4	23,2	29,3	36,9
	10	18,2	22,9	28,9	34,4
	25	17,9	22,5	28,4	35,7
	50	17,7	22,2	28,0	35,3
	100	17,4	21,9	27,6	34,8
20	1	16,6	20,9	26,3	33,1
	5	16,0	20,2	25,4	32,0
	10	15,8	19,9	25,1	31,6
	25	15,5	19,6	24,6	31,0
	50	15,3	19,3	24,3	30,6
	100	15,1	19,0	24,0	30,2
30	1	14,3	18,1	22,7	28,7
	5	13,9	17,4	22,0	27,7
	10	13,6	17,2	21,7	27,3
	25	13,4	16,9	21,2	26,8
	50	13,2	16,6	20,9	26,4
	100	13,0	16,4	20,6	26,0

TEMPERATURE (C°)	YEARS OF SERVICE	PIPE SERIES (S)			
		5	4	3,2	2.5
		Standard Dimension Ratio (SDR)			
		11	9	7,4	6
		ALLOWABLE OPERATING PRESSURE (BAR)			
40	1	12,3	15,5	19,6	24,6
	5	11,9	15,0	18,9	23,8
	10	11,7	14,7	18,6	23,4
	25	11,5	14,4	18,2	22,9
	50	11,3	14,2	17,9	22,6
	100	11,1	14,0	17,6	22,2
50	1	10,5	13,3	16,7	21,0
	5	10,1	12,0	16,1	20,3
	10	10,0	12,6	15,8	19,9
	25	9,7	12,3	15,5	19,5
	50	9,6	12,1	15,2	19,2
	100	9,4	11,9	15,0	18,9
60	1	8,9	11,2	14,2	17,8
	5	8,6	10,8	13,6	17,1
	10	8,4	10,6	13,4	16,8
	25	8,2	10,4	13,1	16,5
	50	8,1	10,2	12,8	16,2
70	1	7,5	9,4	11,9	15,0
	5	7,2	9,1	11,4	14,4
	10	7,0	8,9	11,2	14,1
	25	6,9	8,7	10,9	13,8
	50	6,8	8,5	10,7	13,5
80	1	6,2	7,9	9,9	12,5
	5	6,0	7,5	9,5	12,0
	10	5,9	7,4	9,3	11,7
	25	5,7	7,2	9,1	11,4
95	1	4,7	5,9	7,4	9,4
	5	4,4	5,6	7,1	8,9

SAPPRO PIPES PRODUCTS RANGE

GREEN PPR PIPE 5.8M

ماسورة اخضر 5.8 متر

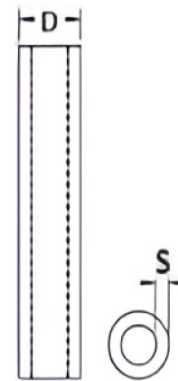

codes / الكود	size / مقاس	D	S	packing / PCS التعبئة
SFP6285205000015	20	20.3	3.4	30
SFP6285205000022	25	25.3	4.2	25
SFP6285205000039	32	32.3	5.4	15
SFP6285205000046	40	40.4	6.7	10
SFP6285205000053	50	50.5	8.3	6
SFP6285205000060	63	63.6	10.5	4
SFP6285205000077	75	75.7	12.5	4
SFP6285205000084	90	90.9	15.0	2
SFP6285205000091	110	111	18.3	2

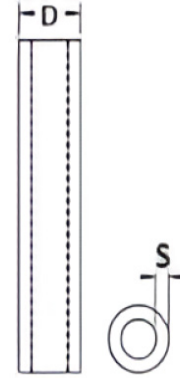
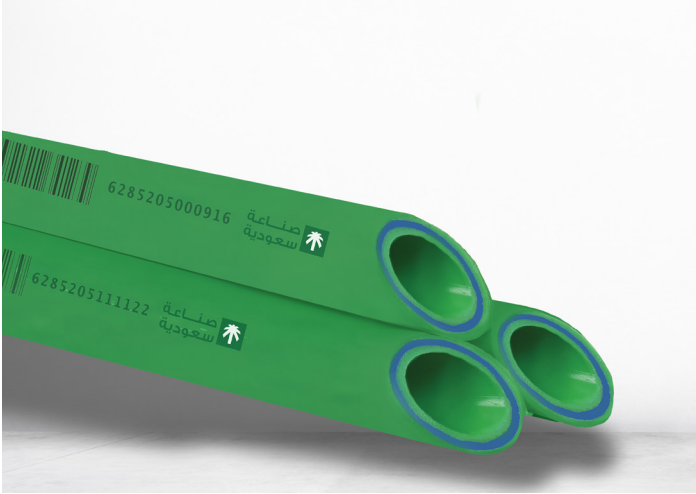

codes / الكود	size / مقاس	D	s	packing /PCS التعبئة
SFP6285205000909	20	20.3	3.4	30
SFP6285205000916	25	25.3	4.2	25
SFP6285205000923	32	32.3	5.4	15
SFP6285205000930	40	40.4	6.7	10
SFP6285205000947	50	50.5	8.3	6
SFP6285205000954	63	63.6	10.5	4
SFP6285205000961	75	75.7	12.5	4
SFP6285205000978	90	90.9	15.0	2
SFP6285205000985	110	111	18.3	2

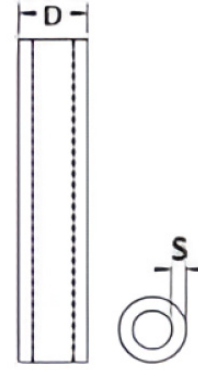

codes / الكود	size / مقاس	D	S	packing /PCS التعبئة
SFP6285205000510	20	20.3	3.4	30
SFP6285205000527	25	25.3	4.2	25
SFP6285205000534	32	32.3	5.4	15
SFP6285205000541	40	40.4	6.7	10
SFP6285205000558	50	50.5	8.3	6
SFP6285205000565	63	63.6	10.5	4
SFP6285205000572	75	75.7	12.5	4
SFP6285205000589	90	90.9	15.0	2
SFP6285205000596	110	111	18.3	2

ANTI UV PIPE BLACK 5.8 M 2 LAYERS
ماسورة 5.8 متر مقاوم للأشعة طبقتين

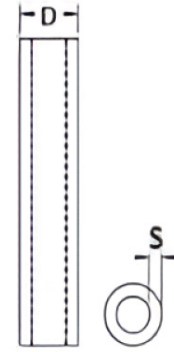
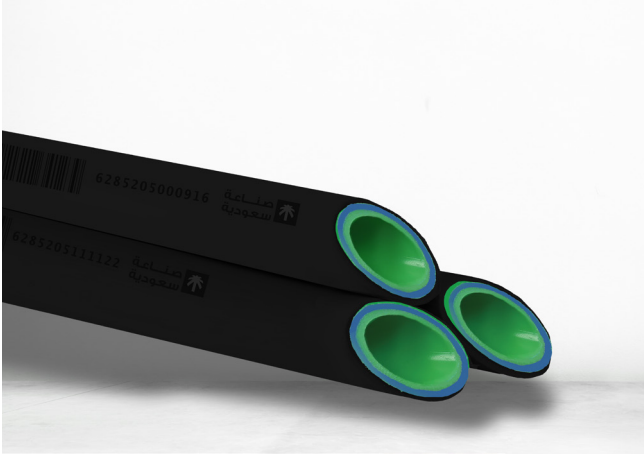

codes / الكود	size / مقاس	D	s	packing /PCS التعبئة
SFP6285205000602	20	20.3	3.4	30
SFP6285205000619	25	25.3	4.2	25
SFP6285205000626	32	32.3	5.4	15
SFP6285205000633	40	40.4	6.7	10
SFP6285205000640	50	50.5	8.3	6
SFP6285205000657	63	63.6	10.5	4
SFP6285205000879	75	75.7	12.5	4
SFP6285205000886	90	90.9	15.0	2
SFP6285205000893	110	111	18.3	2

ماسورة 5.8 متر مقاوم للأشعة فايبر 4 طبقات ANTI UV MULTILAYER Pipes 5.8 M FIBER 4 LAYERS

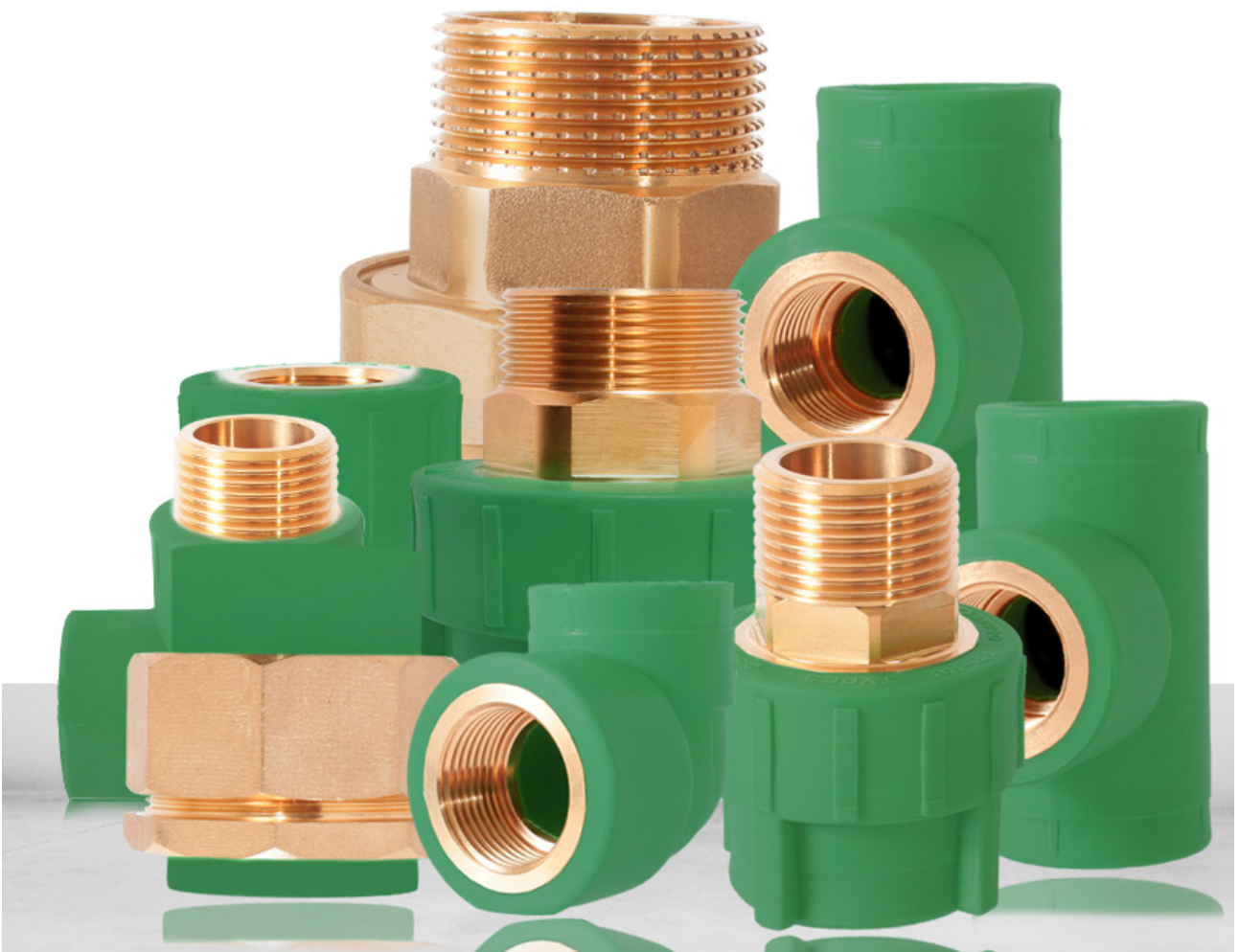

codes / الكود	size / مقاس	D	s	packing / PCS التعبئة
SFP6285205001296	20	20.3	3.4	30
SFP6285205001302	25	25.3	4.2	25
SFP6285205001319	32	32.3	5.4	15
SFP6285205001326	40	40.4	6.7	10
SFP6285205001333	50	50.5	8.3	6
SFP6285205001340	63	63.6	10.5	4
SFP6285205001562	75	75.7	12.5	4
SFP6285205001579	90	90.9	15.0	2
SFP6285205001586	110	111	18.3	2

GREEN FITTINGS PRODUCTS RANGE



CROSSOVER

كوع جمل

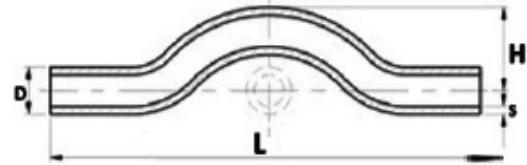
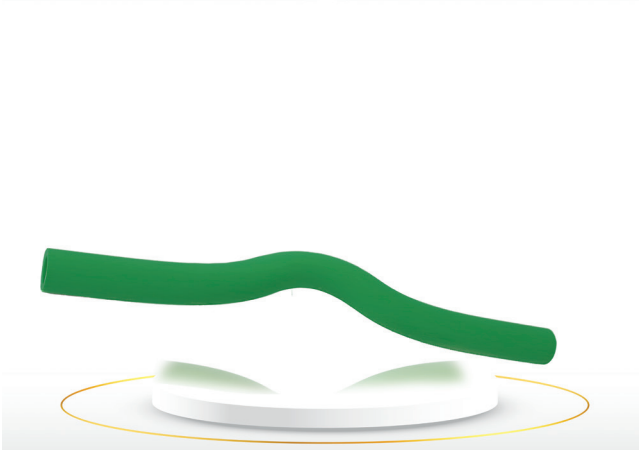

codes / الكود	size / ماس	D	S	L	H	packing / PCS التعبئة / كرتون
SFP6285205001593	20	20.3	3.4	350	43	250
SFP6285205001609	25	25.3	4.2	355	53	125
SFP6285205001616	32	32.3	5.4	360	67	75
SFP6285205001623	40	40.4	6.7	430	84	30
SFP6285205001630	50	50.5	8.3	550	106	25
SFP6285205001647	63	63.6	10.5	650	131	15
SFP6285205001869	75	75.7	12.5	690	154	12
SFP6285205001876	90	90.9	15.0	730	186	8

CROSSOVER WITH SOCKET

كوع جمل بجلبة

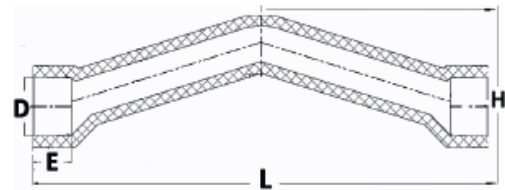

codes / الكود	size / ماس	D	L	E	H	packing / PCS التعبئة / كرتون
SFP6285205002026	20	19.5	185	14.5	41	125
SFP6285205002033	25	24.5	200	16	51	80
SFP6285205002034.1	32	31.5	215	18	65	60

SHORT CROSSOVER

كوع جمل قصير

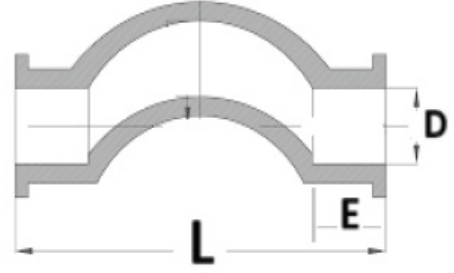

codes / الكود	size / مقاس	D	L	E	packing unit التعبئة
SFP6285205002034	25	24.5	155	14.5	100



ELBOW 90°DEGREE

كوع عادي 90°

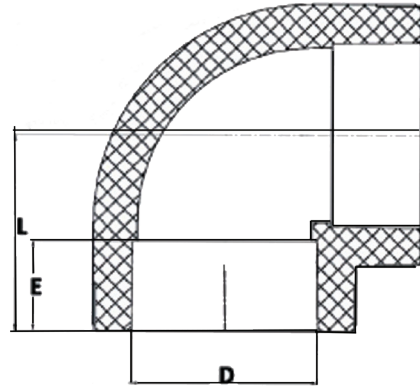

codes / الكود	size / مقاس	D	L	E	packing /PCS التعبئة / كرتون
SFP6285205002613	20	19.5	23	14.5	400
SFP6285205002620	25	24.5	25	16	200
SFP6285205002637	32	31.5	28	18	120
SFP6285205002644	40	39.4	32	20.5	75
SFP6285205002651	50	49.4	37	23.5	40
SFP6285205002668	63	62.5	54	27.5	16
SFP6285205002675	75	74.2	60	31	16
SFP6285205002682	90	89.2	76	35.5	6
SFP6285205002699	110	109.1	84	41.2	3

ELBOW45° DEGREE

كوع فاتح 45°

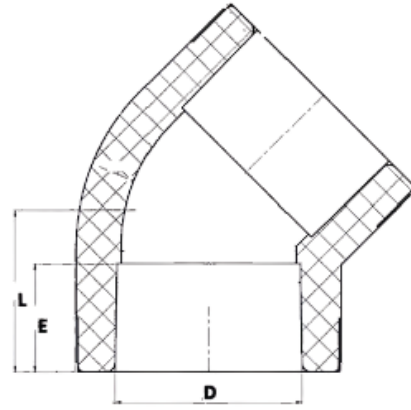

codes / الكود	size / مقاس	D	L	E	packing / PCS التعبئة / كرتون
SFP6285205002798	20	19.5	21	14.5	400
SFP6285205002804	25	24.5	24	16	225
SFP6285205002811	32	31.5	28	18	150
SFP6285205003030	40	39.4	37	20.5	75
SFP6285205003047	50	49.4	48	23.5	50
SFP6285205003054	63	62.5	59	27.5	25
SFP6285205003061	75	74.2	71	31	16
SFP6285205003078	90	89.2	86	35.5	8
SFP6285205003085	110	109.1	104	41.2	3

MALE PLUG

سدة اختبار سن خارجي



codes / الكود	size / مقاس	D	L	E	packing unit التعبئة
SFP6285205004136	20	20.3	56	5	200
SFP6285205004143	25	24.4	58	5	120

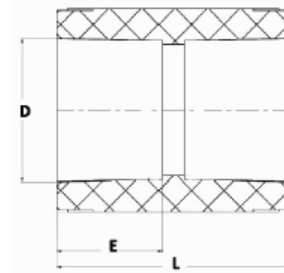
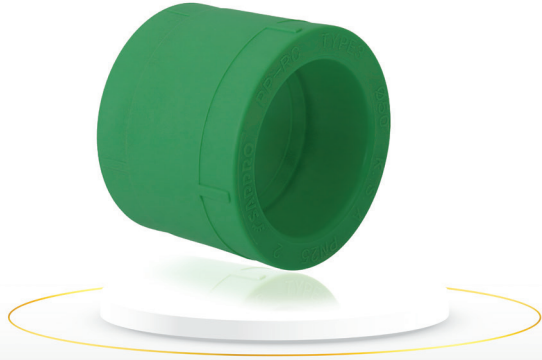

codes / الكود	size / مقاس	D	L	E	packing / PCS التعبئة / كرتون
SFP6285205003221	20	19.5	34	14.5	500
SFP6285205003238	25	24.5	37	16	300
SFP6285205003245	32	31.5	41	18	200
SFP6285205003252	40	39.4	51	20.5	100
SFP6285205003269	50	49.4	66	23.5	60
SFP6285205003276	63	62.5	89	27.5	40
SFP6285205003283	75	74.2	104	31	24
SFP6285205003290	90	89.2	112	35.5	16
SFP6285205003306	110	109.1	121	41.2	9
SFP6285205003290	90	89.2	116	35.5	16
SFP6285205003306	110	109.1	124	41.2	9

PPR SADDLE

سرج

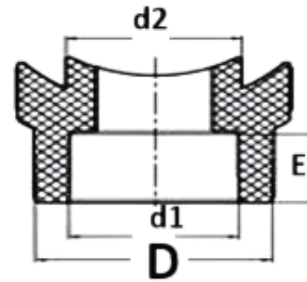
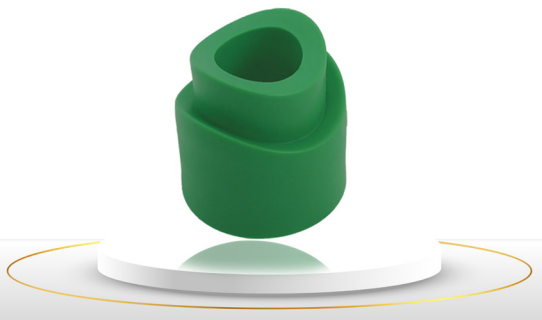

codes / الكود	size / مقاس	D	d1	d2	E	packing / PCS التعبئة / كرتون
SFP6285205008159	32	40	31.5	34	18	200

EQUAL TEE

قسام عادي

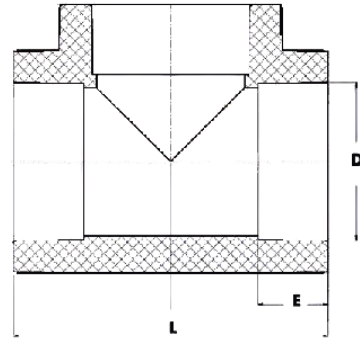

codes / الكود	size / مقاس	D	L	E	packing / PCS التعبئة / كرتون
SFP6285205003566	20	19.5	52	14.5	250
SFP6285205003573	25	24.5	65	16	150
SFP6285205003580	32	31.5	77	18	75
SFP6285205003597	40	39.4	89	20.5	50
SFP6285205003603	50	49.4	112	23.5	24
SFP6285205003610	63	62.5	123	27.5	16
SFP6285205003627	75	74.2	144	31	9
SFP6285205003634	90	89.2	177	35.5	4
SFP6285205003641	110	109.1	194	41.2	2

PPR FLANGE

فلانجه

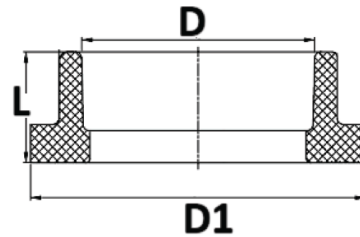
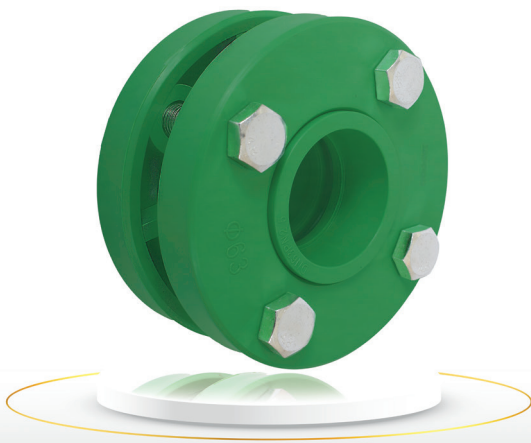

codes / الكود	size / مقاس	D	D1	L	packing unit التعبئة
SFP6285205008067	63	62.5	74	31	3
SFP6285205008068	75	74.2	88	36	3
SFP6285205008069	90	89.2	102	48	2
SFP6285205008070	110	109.1	124	54	2

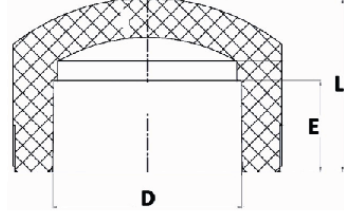
STOPEND CAP
سدة نهاية خط

codes / الكود	size / مقاس	D	L	E	التعبئة / packing unit
SFP6285205003740	20	19.5	24	14.5	500
SFP6285205003962	25	24.5	29	16	450
SFP6285205003979	32	31.5	37	18	280
SFP6285205003986	40	39.4	38	20.5	150
SFP6285205003993	50	49.4	47	23.5	80
SFP6285205004006	63	62.5	68	27.5	60
SFP6285205004013	75	74.2	72	31	40
SFP6285205004020	90	89.2	94	35.5	20
SFP6285205004037	110	109.1	104	41.2	12

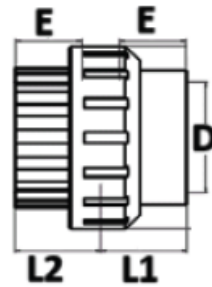
PPR PLASTIC TRANSITION UNION
شد وصل بلاستيك حراري الطرفين

codes / الكود	size / مقاس	D	L1	L2	E	التعبئة / PCS التعبئة / كرتون
SFP6285205004983	20	19.5	27.6	23.1	14.5	200
SFP6285205004990	25	24.5	32.1	26.1	16	150
SFP6285205005003	32	31.5	38.4	33.2	18	75
SFP6285205005010	40	39.4	44.5	38.2	20.5	50
SFP6285205005027	50	49.4	49.1	43.3	23.5	25
SFP6285205005034	63	62.5	54.1	48.5	27.5	12
SFP6285205005041	75	74.2	61.3	54.5	31	8

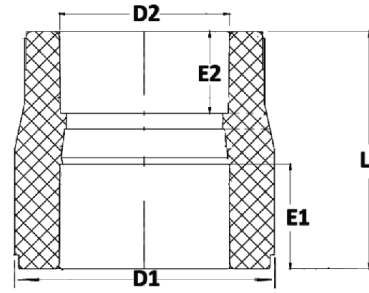

codes / الكود	size / مقاس	D1	L	E1	D2	E2	packing /PCS التعبئة / كرتون
SFP6285205005188	20/25	25	26	16	19.5	14.5	400
SFP6285205005195	20/32	32	28	18	19.5	14.5	300
SFP6285205005201	25/32	32	34	18	24.5	16	300
SFP6285205005218	20/40	40	41	20.5	19.5	14.5	200
SFP6285205005225	25/40	40	42	20.5	24.5	16	150
SFP6285205005232	32/40	40	44	20.5	31.5	18	150
SFP6285205005249	20/50	50	45	23.5	19.5	14.5	100
SFP6285205005256	25/50	50	47	23.5	24.5	16	100
SFP6285205005263	32/50	50	49	23.5	31.5	18	100
SFP6285205005270	40/50	50	51	23.5	39.4	20.5	75
SFP6285205005287	20/63	63	66	27.5	19.5	14.5	60
SFP6285205005294	25/63	63	68	27.5	24.5	16	60
SFP6285205005300	32/63	63	69	27.5	31.5	18	60
SFP6285205005317	40/63	63	71	27.5	39.4	20.5	60
SFP6285205005324	50/63	63	74	27.5	49.4	23.5	40
SFP6285205005325	20/75	75	77	31	19.5	14.5	60
SFP6285205005326	25/75	75	78	31	19.5	16	60
SFP6285205005331	32/75	75	78	31	31.5	18	60
SFP6285205005348	40/75	75	80	31	39.4	20.5	50
SFP6285205005355	50/75	75	81	31	49.4	23.5	40
SFP6285205005362	63/75	75	82	31	62.5	27.5	40
SFP6285205005363	25/90	90	83	35.5	24.5	16	30
SFP6285205005379	32/90	90	84	35.5	31.5	18	30
SFP6285205005379.1	40/90	90	85	35.5	39.4	20.5	30
SFP6285205005386	50/90	90	86	35.5	49.4	23.5	24
SFP6285205005393	63/90	90	86	35.5	62.5	27.5	20
SFP6285205005409	75/90	90	86	35.5	74.2	31	20
SFP6285205005414	40/110	110	94	41.2	39.4	20.5	10
SFP6285205005415	50/110	110	95	41.2	49.4	23.5	10
SFP6285205005416	63/110	110	95	41.2	62.5	27.5	10
SFP6285205005423	75/110	110	96	41.2	74.2	31	10
SFP6285205005430	90/110	110	98	41.2	89.2	35.5	10

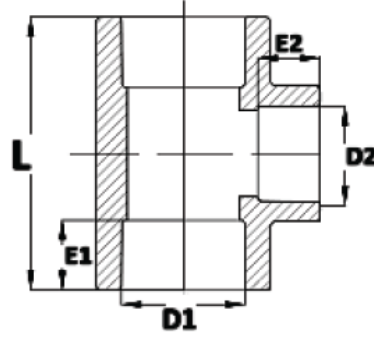

codes / الكود	size / مقاس	D1	L	E1	D2	E2	packing /PCS التعبئة / كرتون
SFP6285205005911	25*20*25	24.5	52	16	19.5	14.5	150
SFP6285205006178	32*20*32	31.5	65	18	19.5	14.5	100
SFP6285205006208	32*25*32	31.5	77	18	24.5	16	100
SFP6285205006215	40*20*40	39.4	78	20.5	19.5	14.5	60
SFP6285205006222	40*25*40	39.4	78	20.5	24.5	16	60
SFP6285205006239	40*32*40	39.4	78	20.5	31.5	18	60
SFP6285205006239.1	50*20*50	49.4	81	23.5	19.5	14.5	30
SFP6285205006604	50*25*50	49.4	81	23.5	24.5	16	30
SFP6285205006628	50*32*50	49.4	81	23.5	31.5	18	30
SFP6285205006635	50*40*50	49.4	84	23.5	39.4	20.5	30
SFP6285205006636	63*20*63	62.5	88	27.5	19.5	14.5	20
SFP6285205006642	63*25*63	62.5	88	27.5	24.5	16	20
SFP6285205006666	63*32*63	62.5	110	27.5	31.5	18	20
SFP6285205006673	63*40*63	62.5	115	27.5	39.4	20.5	20
SFP6285205006680	63*50*63	62.5	122	27.5	49.4	23.5	16
SFP6285205006681	75*20*75	74.2	130	31	19.5	14.5	10
SFP6285205006682	75*25*75	74.2	130	31	19.5	16	10
SFP6285205006697	75*32*75	74.2	133	31	31.5	18	10
SFP6285205006703	75*40*75	74.2	138	31	39.4	20.5	10
SFP6285205006710	75*50*75	74.2	140	31	49.4	23.5	10
SFP6285205006727	75*63*75	74.2	141	31	62.5	27.5	10
SFP6285205006728	90*25*90	89.2	145	35.5	24.5	16	12
SFP6285205006729	90*32*90	89.2	145	35.5	31.5	18	12
SFP6285205006734	90*40*90	89.2	146	35.5	39.4	20.5	12
SFP6285205006741	90*50*90	89.2	146	35.5	49.4	23.5	10
SFP6285205006758	90*63*90	89.2	148	35.5	62.5	27.5	6
SFP6285205006765	90*75*90	89.2	148	35.5	74.2	31	6
SFP6285205006769	110*40*110	109.1	152	41.2	39.4	20.5	3
SFP6285205006772	110*50*110	109.1	152	41.2	49.4	23.5	3
SFP6285205006789	110*63*110	109.1	152	41.2	62.5	27.5	3
SFP6285205006796	110*75*110	109.1	152	41.2	74.2	31	3
SFP6285205006802	110*90*110	109.1	152	41.2	89.2	35.5	3

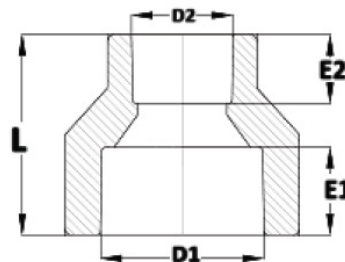

codes / الكود	size / مقاس	D1	L	E1	D2	E2	packing /PCS التعبئة / كرتون
SFP6285205007267	25*20	24.5	26	16	19.5	14.5	400
SFP6285205007274	32*20	31.5	28	18	19.5	14.5	250
SFP6285205007281	32*25	31.5	34	18	24.5	16	250
SFP6285205007298	40*20	39.4	41	20.5	19.5	14.5	150
SFP6285205007304	40*25	39.4	42	20.5	24.5	16	150
SFP6285205007311	40*32	39.4	44	20.5	31.5	18	100
SFP6285205007312	50*20	49.4	45	23.5	19.5	14.5	100
SFP6285205007313	50*25	49.4	47	23.5	24.5	16	100
SFP6285205007314	50*32	49.4	49	23.5	31.5	18	100
SFP6285205007315	50*40	49.4	51	23.5	39.4	20.5	75
SFP6285205007316	63*20	62.5	66	27.5	19.5	14.5	60
SFP6285205007317	63*25	62.5	68	27.5	24.5	16	60
SFP6285205007318	63*32	62.5	69	27.5	31.5	18	60
SFP6285205007319	63*40	62.5	71	27.5	39.4	20.5	60
SFP6285205007320	63*50	62.5	74	27.5	49.4	23.5	40
SFP6285205007320.1	75*25	74.2	78	31	19.5	16	60
SFP6285205007321	75*32	74.2	78	31	31.5	18	60
SFP6285205007322	75*40	74.2	80	31	39.4	20.5	50
SFP6285205007323	75*50	74.2	81	31	49.4	23.5	40
SFP6285205007324	75*63	74.2	82	31	62.5	27.5	40
SFP6285205007325	90*25	89.2	83	35.5	24.5	16	24
SFP6285205007326	90*32	89.2	84	35.5	31.5	18	24
SFP6285205007330	90*40	89.2	85	35.5	39.4	20.5	24
SFP6285205007331	90*50	89.2	86	35.5	49.4	23.5	24
SFP6285205007332	90*63	89.2	86	35.5	62.5	27.5	24
SFP6285205007333	90*75	89.2	86	35.5	74.2	31	20
SFP6285205007335.1	110*40	109.1	94	41.2	39.4	20.5	9
SFP6285205007335.2	110*50	109.1	102	41.2	49.4	23.5	9
SFP6285205007336	110*63	109.1	102	41.2	62.5	27.5	9
SFP6285205007337	110*75	109.1	103	41.2	74.2	31	9
SFP6285205007338	110*90	109.1	103	41.2	89.2	35.5	6

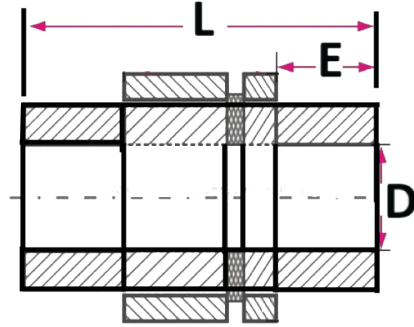
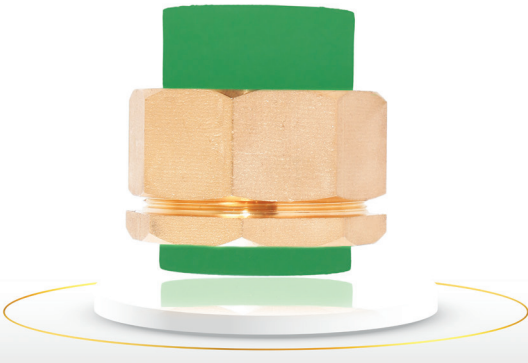

codes / الكود	size / مقاس	D	L	E	packing /PCS التعبئة / كرتون
SFP6285205004419	20	19.5	75	14.5	60
SFP6285205004464	25	24.5	80	16	40
SFP6285205004471	32	31.5	87	18	30
SFP6285205004488	40	39.4	93	20.5	20
SFP6285205004495	50	49.4	102	23.5	15
SFP6285205004501	63	62.5	112	27.5	10
SFP6285205004518	75	74.2	125	31	6
SFP6285205004525	90	89.2	138	35.5	2
SFP6285205004600	110	109.1	144	41.2	2

FEMALE BRASS DOUBLE ELBOW

ميزان خراط بسن داخلي

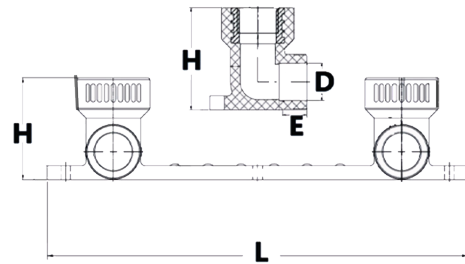

codes / الكود	size / مقاس	D	L	E	H	packing /PCS التعبئة / كرتون
SFP6285205007458	25*1/2	24.5	216.5	14.5	52.2	20
SFP6285205007459	25* 3/4	24.5	216.5	14.5	56.3	20

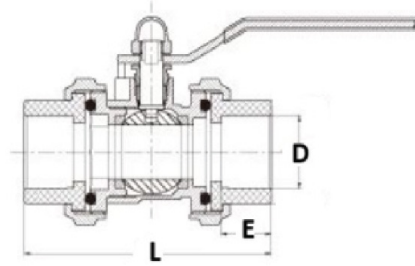
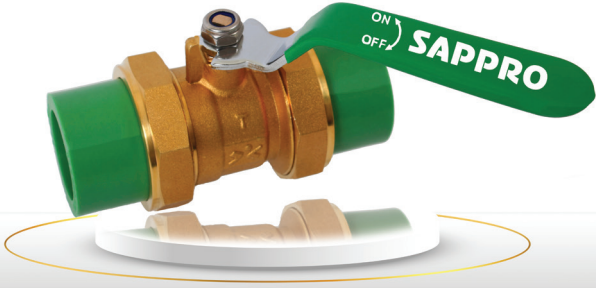

codes / الكود	size / مقاس	D	L	E	packing /PCS التعبئة / كرتون
SFP6285205007384	20	19.5	78	14.5	30
SFP6285205007385	25	24.5	86	16	30
SFP6285205007386	32	31.5	102	18	15
SFP6285205007387	40	39.4	117	20.5	15
SFP6285205007388	50	49.4	146	23.5	10
SFP6285205007389	63	62.5	165	27.5	6
SFP6285205007390	75	74.2	181	31	3
SFP6285205007391	90	89.2	207	35.5	2
SFP6285205007391.1	110	109.1	225	41.2	2

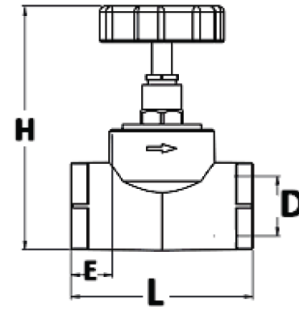

codes / الكود	size / مقاس	D	L	E	H	packing /PCS التعبئة / كرتون
SFP6285205007399	20	19.5	73	14.5	96	25
SFP6285205007400	25	24.5	73	16	105	20
SFP6285205007401	32	31.5	86	18	109	15
SFP6285205007402	40	39.4	93	20.5	129	10
SFP6285205007403	50	49.4	103	23.5	138	8
SFP6285205007404	63	62.5	114	27.5	152	6

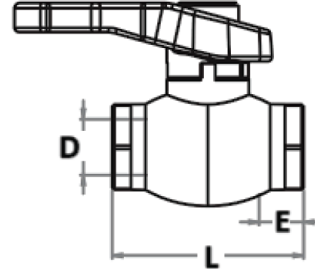

codes / الكود	size / مقاس	D	L	E	packing /PCS التعبئة / كرتون
SFP6285205007368	20	19.5	66	14.5	30
SFP6285205007369	25	24.5	73	16	30
SFP6285205007370	32	31.5	88	18	20
SFP6285205007371	40	39.4	105	20.5	10
SFP6285205007372	50	49.4	125	23.5	8
SFP6285205007373	63	62.5	150	27.5	4
SFP6285205007374	75	74.2	165	31	4

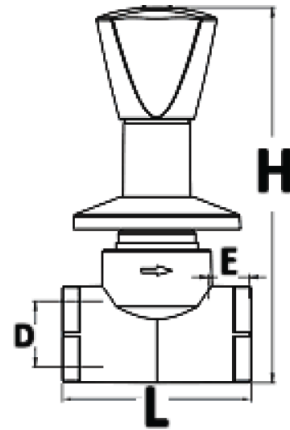

codes / الكود	size / مقاس	D	L	E	H	packing /PCS التعبئة / كرتون
SFP6285205007435	20*3/4	19.5	73	14.5	140	10
SFP6285205007437	25*3/4	24.5	73	16	140	10
SFP6285205007439	32*3/4	31.5	86	18	148	10
SFP6285205007440	32*1	31.5	86	18	148	10
SFP6285205007441	40	39.4	93	20.5	154	10
SFP6285205007442	50	49.4	103	23.5	163	8

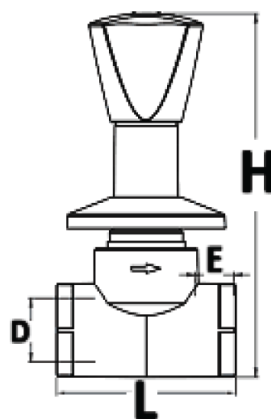

codes / الكود	size / مقاس	D	L	E	H	packing /PCS التعبئة / كرتون
SFP6285205007436	25*3/4	24.5	73	16	140	10
SFP6285205007438	32*1	31.5	86	18	148	10

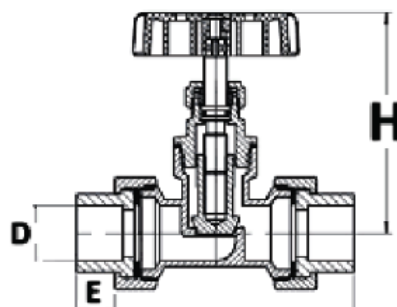

codes / الكود	size / مقاس	D	L	E	H	packing /PCS التعبئة / كرتون
SFP6285205007417	20	19.5	78	14.5	96	25
SFP6285205007418	25	24.5	86	16	105	20
SFP6285205007419	32	31.5	102	18	109	15
SFP6285205007420	40	39.4	117	20.5	129	10
SFP6285205007421	50	49.4	146	23.5	138	8
SFP6285205007422	63	62.5	168	27.5	152	6
SFP6285205007423	75	74.2	186	31	164	4
SFP6285205007424	90	89.2	215	35.5	188	2
SFP6285205007425	110	109.1	233	41.2	208	2

SIPHONE VALVE (MEDIUM/HEAVY)

محبس سيفون دفن وسط / ثقيل

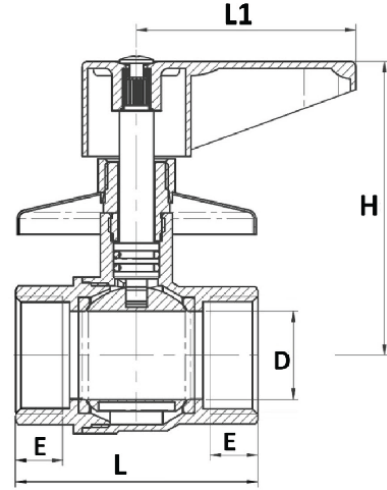

codes / الكود	size / مقاس	D	L	L1	E	H	packing /PCS التعبئة / كرتون
SFP6285205007453	25	24.5	73	60	16	110	4
SFP6285205007455	25	24.5	73	60	16	110	4
SFP6285205007456	32	31.5	88	66	18	115	4
SFP6285205007457	32	31.5	88	66	18	115	4
SFP6285205007457.0	40	39.4	105	88	20.5	133	2
SFP6285205007457.00	50	49.4	125	91	23.5	138	2

FEMALE BRASS TEE

قسام سن داخلي ذهبي

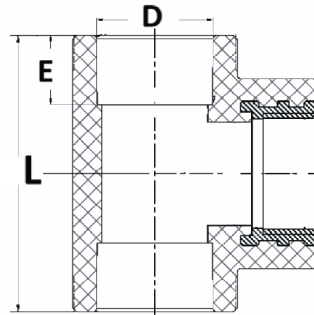
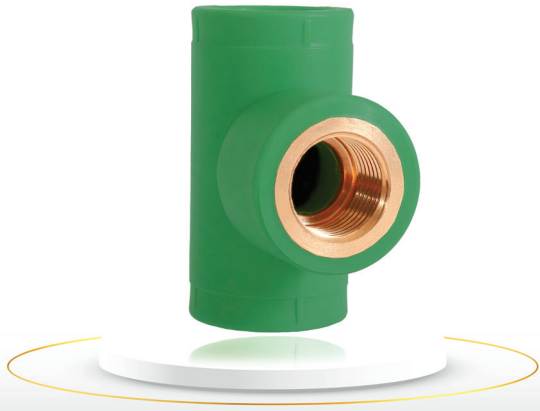

codes / الكود	size / مقاس	D	L	E	packing /PCS التعبئة / كرتون
SFP6285205007597	20 * 1/2	19.5	52	14.5	100
SFP6285205007598	20 * 3/4	19.5	52	14.5	75
SFP6285205007599-1	25 * 1/2	24.5	72	16	60
SFP6285205007600	25 * 3/4	24.5	72	16	60
SFP6285205007601	32 * 1/2	31.5	86	18	30
SFP6285205007602	32 * 3/4	31.5	86	18	30
SFP6285205007603	32 * 1	31.5	86	18	30

MALE BRASS TEE

قسم سن خارجي

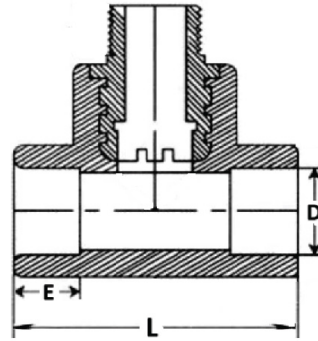
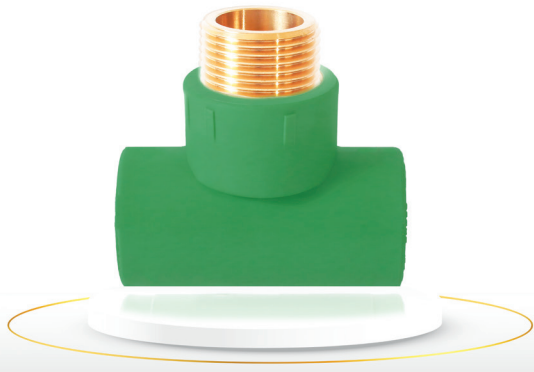

codes / الكود	size / مقاس	D	L	E	packing /PCS التعبئة / كرتون
SFP6285205007611	20 * 1/2	19.5	52	14.5	75
SFP6285205007612	20 * 3/4	19.5	52	14.5	75
SFP6285205007613	25 * 1/2	24.5	72	16	60
SFP6285205007614	25 * 3/4	24.5	72	16	60
SFP6285205007615	32 * 1/2	31.5	86	18	40
SFP6285205007616	32 * 3/4	31.5	86	18	20
SFP6285205007617	32 * 1	31.5	86	18	20



FEMALE BRASS SOCKET

جلبة سن داخلي ذهبي

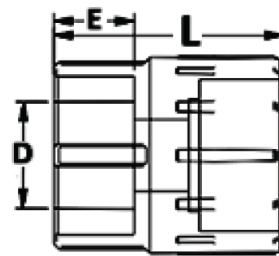

codes / الكود	size / مقاس	D	L	E	packing /PCS التعبئة / كرتون
SFP6285205007625	20*1/2	19.5	38	14.5	120
SFP6285205007626	20*3/4	19.5	42	14.5	100
SFP6285205007627	25*1/2	24.5	43	16	120
SFP6285205007628	25*3/4	24.5	44	16	100
SFP6285205007629	32*1/2	31.5	46	18	50
SFP6285205007630	32*3/4	31.5	45	18	50
SFP6285205007631	32*1	31.5	48	18	50

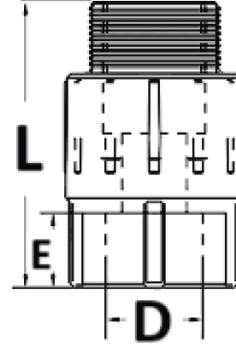
MALE BRASS SOCKET
جلبة سن خارجي ذهبي

codes / الكود	size / مقاس	D	L	E	packing unit التعبئة
SFP6285205007660	20*1/2	19.5	45	14.5	120
SFP6285205007661	20*3/4	19.5	46	14.5	100
SFP6285205007662	25*1/2	24.5	47	16	120
SFP6285205007663	25*3/4	24.5	48	16	100
SFP6285205007664	32*1/2	31.5	48	18	40
SFP6285205007665	32*3/4	31.5	51	18	40
SFP6285205007666	32*1	31.5	54	18	30

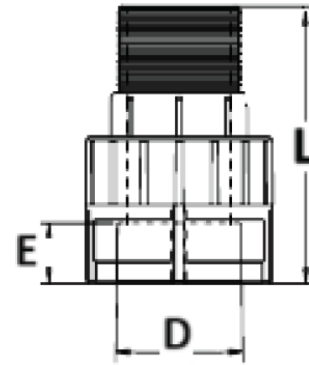
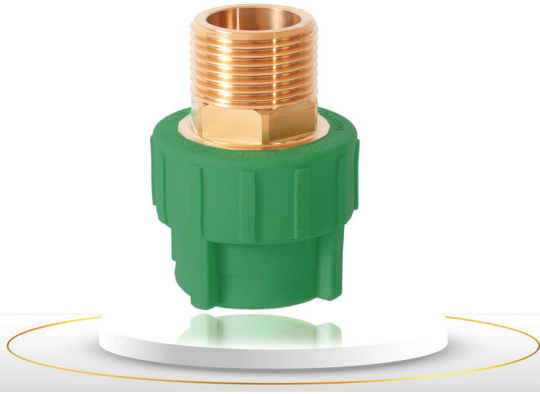
MALE HEXAGON BRASS SOCKET
جلبة سن خارجي ذهبي سداسي

codes / الكود	size / مقاس	D	L	E	packing / PCS التعبئة / كرتون
SFP6285205008025	32*1	31.5	80	18	30
SFP6285205008027	40*1.1/4	39.4	81	20.5	20
SFP6285205008028	50*1.1/2	49.4	90	23.5	15
SFP6285205008029	63*2	62.5	95	27.5	10
SFP6285205008030	75*2.1/2	74.2	108	31	8
SFP6285205008031	90*3	89.2	140	35.5	4
SFP6285205008031.1	110*4	109.1	153	41.2	2

FEMALE HEXAGON BRASS SOCKET

جلبة سن داخلي ذهبي سداسي

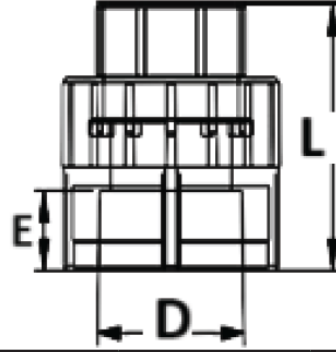
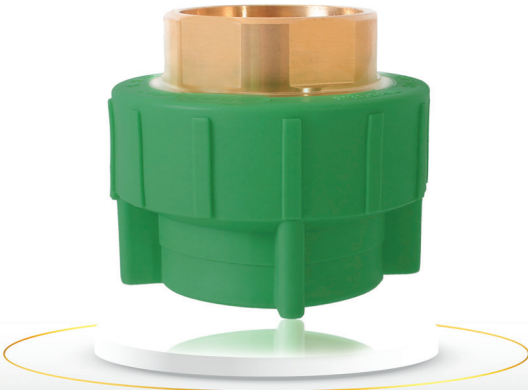

codes / الكود	size / مقاس	D	L	E	packing unit التعبئة
SFP6285205008015	32*1	31.5	55	18	50
SFP6285205008016	40*1.1/4	39.4	65	20.5	15
SFP6285205008017	50*1.1/2	49.4	70	23.5	15
SFP6285205008018	63*2	62.5	75	27.5	10
SFP6285205008018.1	75*2.1/2	74.2	80	31	8
SFP6285205008019	90*3	89.2	105	35.5	4
SFP6285205008019.1	110*4	109.1	110	41.2	2

FEMALE BRASS ELBOW 90°

كوع سن داخلي 90°

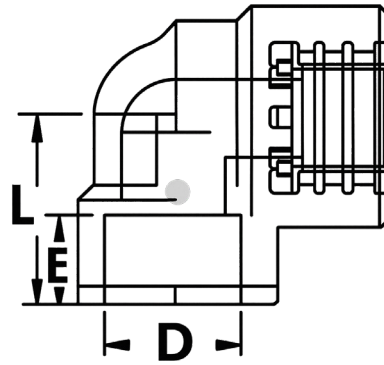

codes / الكود	size / مقاس	D	L	E	packing unit التعبئة
SFP6285205008039	20 * 1/2	19.5	35	14.5	100
SFP6285205008040	20 * 3/4	19.5	35	14.5	100
SFP6285205008041	25 * 1/2	24.5	40	16	90
SFP6285205008042	25 * 3/4	24.5	40	16	75
SFP6285205008043	32 * 1/2	31.5	45	18	40
SFP6285205008044	32 * 3/4	31.5	45	18	40
SFP6285205008045	32 * 1	31.5	45	18	40

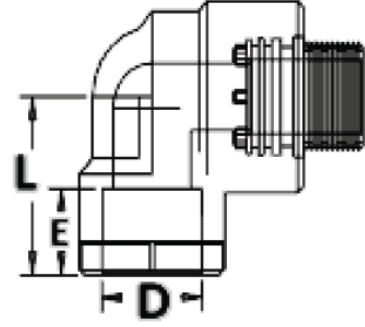

codes / الكود	size / مقاس	D	L	E	packing /PCS التعبئة / كرتون
SFP6285205008053	20 * 1/2	19.5	33	14.5	75
SFP6285205008054	20 * 3/4	19.5	34	14.5	75
SFP6285205008055	25 * 1/2	24.5	36	16	75
SFP6285205008056	25 * 3/4	24.5	36	16	60
SFP6285205008056.1	32 * 1/2	31.5	43	18	40
SFP6285205008057	32 * 3/4	31.5	43	18	40
SFP6285205008058	32 * 1	31.5	45	18	30

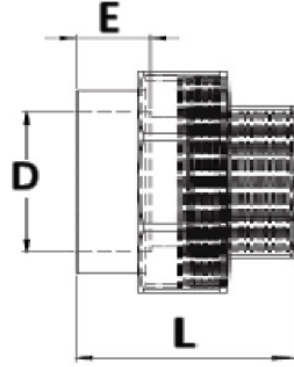

codes / الكود	size / مقاس	D	L	E	packing /PCS التعبئة / كرتون
SFP6285205008089	20*1/2	19.5	49	14.5	50
SFP6285205008090	25*3/4	24.5	58	16	40
SFP6285205008091	32* 3/4	31.5	68	18	30
SFP6285205008092	32*1	31.5	81	18	30
SFP6285205008093	40* 1-1/4	39.4	89	20.5	30
SFP6285205008094	50* 1-1/2	49.4	105	23.5	15
SFP6285205008095	63* 2	62.5	120	27.5	8
SFP6285205008096	75* 2-1/2	74.2	168	31	6
SFP6285205008097	90 * 3	89.2	178	35.5	6

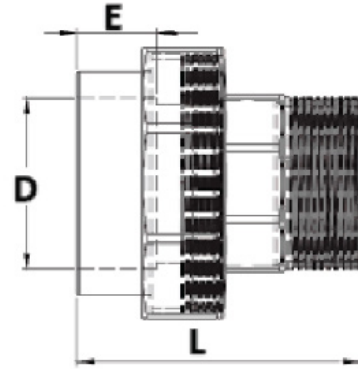
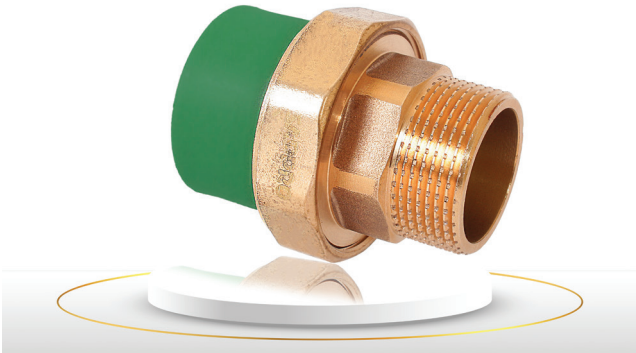

codes / الكود	size / مقاس	D	L	E	packing /PCS التعبئة / كرتون
SFP6285205008106	20*1/2	19.5	58	14.5	50
SFP6285205008107	25*3/4	24.5	65	16	40
SFP6285205008108	32*3/4	31.5	74	18	40
SFP6285205008109	32*1	31.5	87	18	30
SFP6285205008111	40*1.1/4	39.4	98	20.5	30
SFP6285205008112	50*1.1/2	49.4	112	23.5	20
SFP6285205008113	63*2	62.5	128	27.5	8
SFP6285205008114	75*2.1/2	74.2	178	31	6
SFP6285205008115	90*3	89.2	188	35.5	4

UV BLACK FITTINGS PRODUCTS RANGE



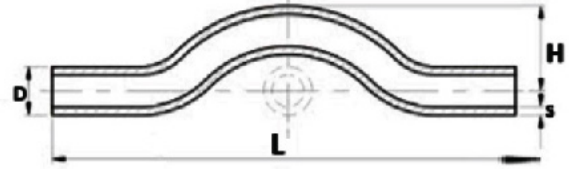

codes / الكود	size / مقاس	D	s	L	H	packing / PCS التعبئة / كرتون
SFP6285205001890	20	20.3	3.4	350	43	250
SFP6285205001906	25	25.3	4.2	355	53	125
SFP6285205001944	32	32.3	5.4	360	67	75
SFP6285205001968	40	40.4	6.7	430	84	30
SFP6285205001975	50	50.5	8.3	550	106	25
SFP6285205001982	63	63.6	10.5	650	131	15
SFP6285205001999	75	75.7	12.5	690	154	12
SFP6285205002002	90	90.9	15.0	730	186	8

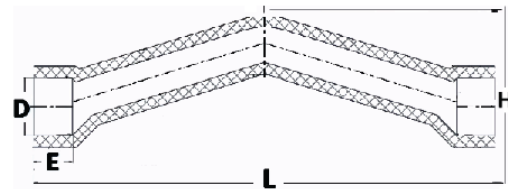

codes / الكود	size / مقاس	D	L	E	H	packing / PCS التعبئة / كرتون
SFP6285205002316	20	19.5	185	14.5	41	125
SFP6285205002323	25	24.5	200	16	51	80
SFP6285205002330	32	31.5	215	18	65	60

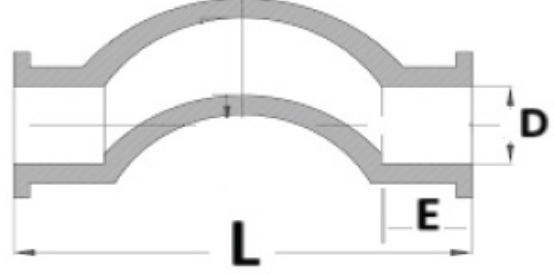
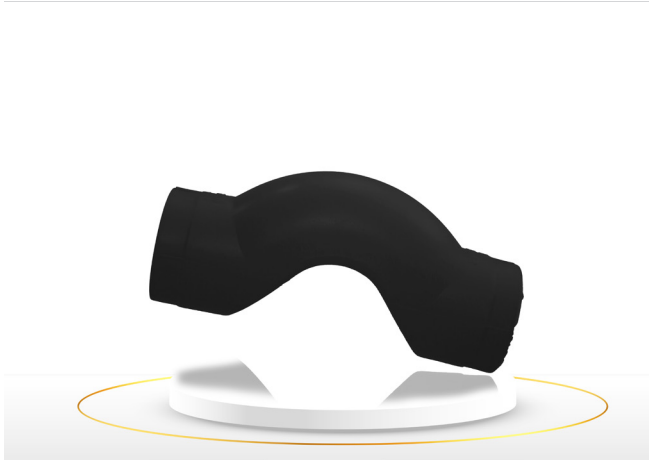

codes / الكود	size / مقاس	D	L	E	packing /PCS التعبئة / كرتون
SFP6285205002324	25	24.5	155	14.5	100

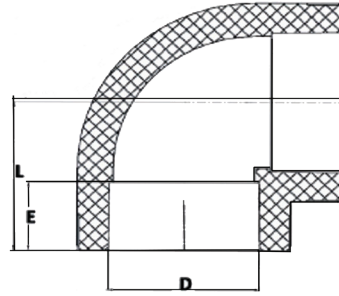

codes / الكود	size / مقاس	D	L	E	packing /PCS التعبئة / كرتون
SFP6285205002705	20	19.5	23	14.5	400
SFP6285205002712	25	24.5	25	16	200
SFP6285205002729	32	31.5	28	18	120
SFP6285205002736	40	39.4	32	20.5	75
SFP6285205002743	50	49.4	37	23.5	40
SFP6285205002750	63	62.5	54	27.5	16
SFP6285205002767	75	74.2	60	31	16
SFP6285205002774	90	89.2	76	35.5	6
SFP6285205002781	110	109.1	84	41.2	3

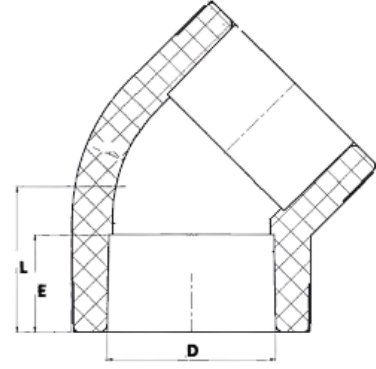

codes / الكود	size / مقاس	D	L	E	packing /PCS التعبئة / كرتون
SFP6285205003139	20	19.5	21	14.5	400
SFP6285205003146	25	24.5	24	16	225
SFP6285205003153	32	31.5	28	18	150
SFP6285205003160	40	39.4	37	20.5	75
SFP6285205003177	50	49.4	48	23.5	50
SFP6285205003184	63	62.5	59	27.5	25
SFP6285205003191	75	74.2	71	31	16
SFP6285205003207	90	89.2	86	35.5	8
SFP6285205003214	110	109.1	104	41.2	3

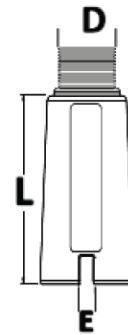

codes / الكود	size / مقاس	D	L	E	packing /PCS التعبئة / كرتون
SFP6285205004167	20	20.3	56	5	200
SFP6285205004372	25	24.4	58	5	120

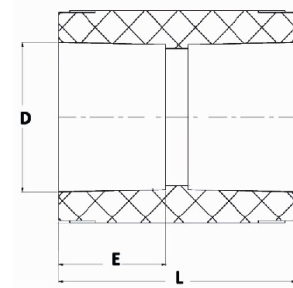

codes / الكود	size / مقاس	D	L	E	packing / PCS التعبئة / كرتون
SFP6285205003313	20	19.5	34	14.5	500
SFP6285205003320	25	24.5	37	16	300
SFP6285205003337	32	31.5	41	18	200
SFP6285205003344	40	39.4	51	20.5	100
SFP6285205003351	50	49.4	66	23.5	60
SFP6285205003368	63	62.5	89	27.5	40
SFP6285205003375	75	74.2	104	31	24
SFP6285205003382	90	89.2	112	35.5	16
SFP6285205003399	110	109.1	121	41.2	9

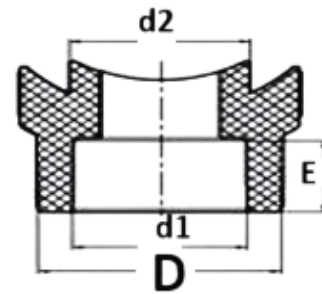
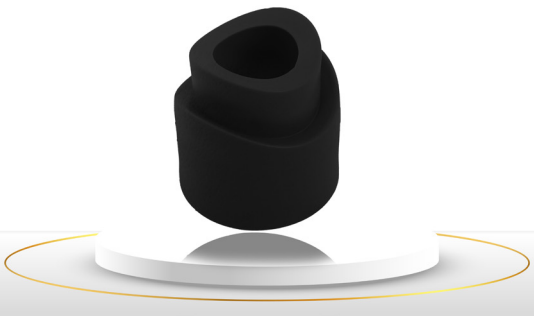

codes / الكود	size / مقاس	D	d1	d2	E	packing / PCS التعبئة / كرتون
SFP6285205008160	32	40	31.5	34	18	200

ANTI UV EQUAL TEE

قسام عادي مقاوم للأشعة

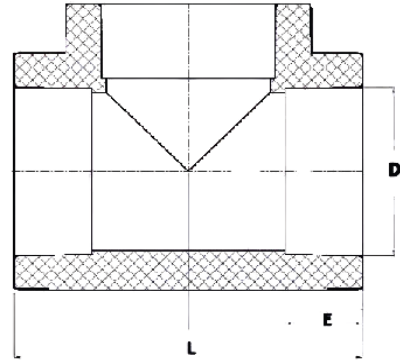

codes / الكود	size / مقاس	D	L	E	packing /PCS التعبئة / كرتون
SFP6285205003658	20	19.5	52	14.5	250
SFP6285205003665	25	24.5	65	16	150
SFP6285205003672	32	31.5	77	18	75
SFP6285205003689	40	39.4	89	20.5	50
SFP6285205003696	50	49.4	112	23.5	24
SFP6285205003702	63	62.5	123	27.5	16
SFP6285205003719	75	74.2	144	31	9
SFP6285205003726	90	89.2	177	35.5	4
SFP6285205003733	110	109.1	194	41.2	2



ANTI UV FLANGE

فلانجه مقاوم للأشعة

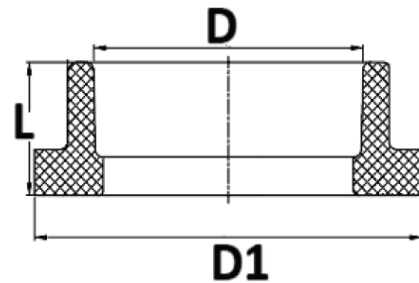
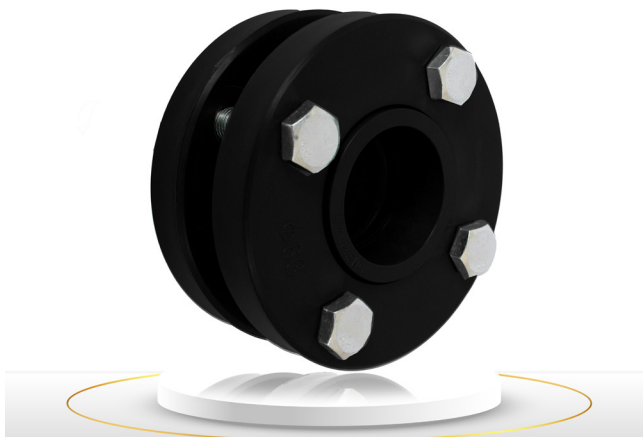

codes / الكود	size / مقاس	D	D1	L	packing /PCS التعبئة / كرتون
SFP6285205008073	63	62.5	74	31	3
SFP6285205008074	75	74.2	88	36	3
SFP6285205008075	90	89.2	102	48	2
SFP6285205008076	110	109.1	124	54	2

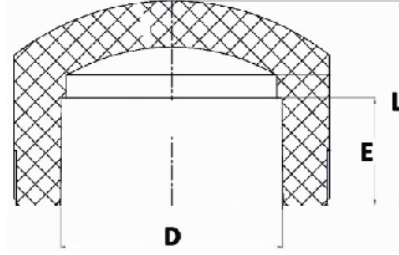
ANTI UV STOPEND ENDCAP
سدة نهاية خط مقاوم للأشعة

codes / الكود	size / مقاس	D	L	E	packing /PCS التعبئة / كرتون
SFP6285205004044	20	19.5	24	14.5	500
SFP6285205004051	25	24.5	29	16	450
SFP6285205004068	32	31.5	37	18	280
SFP6285205004075	40	39.4	38	20.5	150
SFP6285205004082	50	49.4	47	23.5	80
SFP6285205004099	63	62.5	68	27.5	60
SFP6285205004105	75	74.2	72	31	40
SFP6285205004112	90	89.2	94	35.5	20
SFP6285205004129	110	109.1	104	41.2	12

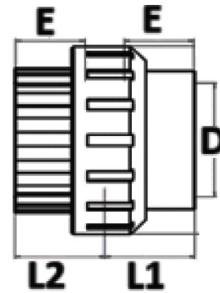
ANTI UV TRANSITIONPPR UNION
شد وصل بلاستيك حراري الطرفين مقاوم للأشعة

codes / الكود	size / مقاس	D	L1	L2	E	packing /PCS التعبئة / كرتون
SFP6285205005072	20	19.5	27.6	23.1	14.5	200
SFP6285205005102	25	24.5	32.1	26.1	16	150
SFP6285205005119	32	31.5	38.4	33.2	18	75
SFP6285205005126	40	39.4	44.5	38.2	20.5	50
SFP6285205005133	50	49.4	49.1	43.3	23.5	25
SFP6285205005140	63	62.5	54.1	48.5	27.5	12
SFP6285205005157	75	74.2	61.3	54.5	31	8

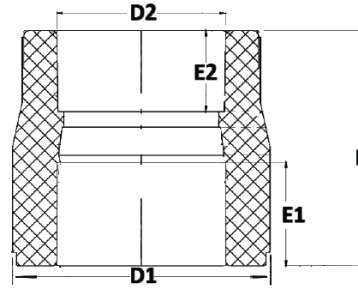

codes / الكود	size / مقاس	D1	L	E1	D2	E2	packing / PCS التعبئة / كرتون
SFP6285205005447	20/25	25	26	16	19.5	14.5	400
SFP6285205005454	20/32	32	28	18	19.5	14.5	300
SFP6285205005683	25/32	32	34	18	24.5	16	300
SFP6285205005690	20/40	40	41	20.5	19.5	14.5	200
SFP6285205005706	25/40	40	42	20.5	24.5	16	150
SFP6285205005713	32/40	40	44	20.5	31.5	18	150
SFP6285205005720	20/50	50	45	23.5	19.5	14.5	100
SFP6285205005737	25/50	50	47	23.5	24.5	16	100
SFP6285205005744	32/50	50	49	23.5	31.5	18	100
SFP6285205005748	40/50	50	51	23.5	39.4	20.5	75
SFP6285205005751	20/63	63	66	27.5	19.5	14.5	60
SFP6285205005765	25/63	63	68	27.5	24.5	16	60
SFP6285205005768	32/63	63	69	27.5	31.5	18	60
SFP6285205005775	40/63	63	71	27.5	39.4	20.5	60
SFP6285205005782	50/63	63	74	27.5	49.4	23.5	40
SFP6285205005783	20/75	75	77	31	19.5	14.5	60
SFP6285205005784	25/75	75	78	31	19.5	16	60
SFP6285205005799	32/75	75	78	31	31.5	18	60
SFP6285205005805	40/75	75	80	31	39.4	20.5	50
SFP6285205005812	50/75	75	81	31	49.4	23.5	40
SFP6285205005829	63/75	75	82	31	62.5	27.5	40
SFP6285205005830	25/90	90	83	35.5	24.5	16	30
SFP6285205005836	32/90	90	84	35.5	31.5	18	30
SFP6285205005836.1	40/90	90	85	35.5	39.4	20.5	30
SFP6285205005843	50/90	90	86	35.5	49.4	23.5	24
SFP6285205005850	63/90	90	86	35.5	62.5	27.5	20
SFP6285205005867	75/90	90	86	35.5	74.2	31	20
SFP6285205005867.2	40/110	110	94	41.2	39.4	20.5	10
SFP6285205005867.3	50/110	110	95	41.2	49.4	23.5	10
SFP6285205005874	63/110	110	95	41.2	62.5	27.5	10
SFP6285205005881	75/110	110	96	41.2	74.2	31	10
SFP6285205005898	90/110	110	98	41.2	89.2	35.5	10

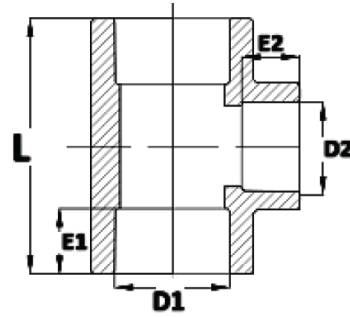

codes / الكود	size / مقاس	D1	L	E1	D2	E2	packing /PCS التعبئة / كرتون
SFP62852050068212	25*20*25	24.5	52	16	19.5	14.5	150
SFP6285205006826	32*20*32	31.5	65	18	19.5	14.5	100
SFP6285205006842	32*25*32	31.5	77	18	24.5	16	100
SFP6285205006843	40*20*40	39.4	78	20.5	19.5	14.5	60
SFP6285205006845	40*25*40	39.4	78	20.5	24.5	16	60
SFP6285205006847	40*32*40	39.4	78	20.5	31.5	18	60
SFP6285205006847.1	50*20*50	49.4	81	23.5	19.5	14.5	30
SFP6285205006848	50*25*50	49.4	81	23.5	24.5	16	30
SFP6285205006857	50*32*50	49.4	81	23.5	31.5	18	30
SFP6285205006864	50*40*50	49.4	84	23.5	39.4	20.5	30
SFP6285205006871	63*20*63	62.5	88	27.5	19.5	14.5	20
SFP6285205006888	63*25*63	62.5	88	27.5	24.5	16	20
SFP6285205006895	63*32*63	62.5	110	27.5	31.5	18	20
SFP6285205006901	63*40*63	62.5	115	27.5	39.4	20.5	20
SFP6285205006918	63*50*63	62.5	122	27.5	49.4	23.5	16
SFP6285205006918.1	75*20*75	74.2	130	31	19.5	14.5	10
SFP6285205006918.2	75*25*75	74.2	130	31	19.5	16	10
SFP6285205006925	75*32*75	74.2	133	31	31.5	18	10
SFP6285205007151	75*40*75	74.2	138	31	39.4	20.5	10
SFP6285205007168	75*50*75	74.2	140	31	49.4	23.5	10
SFP6285205007175	75*63*75	74.2	141	31	62.5	27.5	10
SFP6285205007176	90*25*90	89.2	145	35.5	24.5	16	12
SFP6285205007175.1	90*32*90	89.2	145	35.5	31.5	18	12
SFP6285205007182	90*40*90	89.2	146	35.5	39.4	20.5	12
SFP6285205007199	90*50*90	89.2	146	35.5	49.4	23.5	10
SFP6285205007205	90*63*90	89.2	148	35.5	62.5	27.5	6
SFP6285205007212	90*75*90	89.2	148	35.5	74.2	31	6
SFP6285205007212.4	110*40*110	109.1	152	41.2	39.4	20.5	3
SFP6285205007229	110*50*110	109.1	152	41.2	49.4	23.5	3
SFP6285205007236	110*63*110	109.1	152	41.2	62.5	27.5	3
SFP6285205007243	110*75*110	109.1	152	41.2	74.2	31	3
SFP6285205007250	110*90*110	109.1	152	41.2	89.2	35.5	3

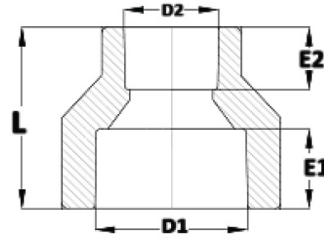

codes / الكود	size / مقاس	D1	L	E1	D2	E2	packing / التعبئة PCS / كرتون
SFP6285205007339	25*20	24.5	26	16	19.5	14.5	400
SFP6285205007340	32*20	31.5	28	18	19.5	14.5	250
SFP6285205007341	32*25	31.5	34	18	24.5	16	250
SFP6285205007342	40*20	39.4	41	20.5	19.5	14.5	150
SFP6285205007343	40*25	39.4	42	20.5	24.5	16	150
SFP6285205007344	40*32	39.4	44	20.5	31.5	18	100
SFP6285205007345	50*20	49.4	45	23.5	19.5	14.5	100
SFP6285205007346	50*25	49.4	47	23.5	24.5	16	100
SFP6285205007347	50*32	49.4	49	23.5	31.5	18	100
SFP6285205007348	50*40	49.4	51	23.5	39.4	20.5	75
SFP6285205007349	63*20	62.5	66	27.5	19.5	14.5	60
SFP6285205007350	63*25	62.5	68	27.5	24.5	16	60
SFP6285205007351	63*32	62.5	69	27.5	31.5	18	60
SFP6285205007352	63*40	62.5	71	27.5	39.4	20.5	60
SFP6285205007353	63*50	62.5	74	27.5	49.4	23.5	40
SFP6285205007353.1	75*25	74.2	78	31	19.5	16	60
SFP6285205007354	75*32	74.2	78	31	31.5	18	60
SFP6285205007355	75*40	74.2	80	31	39.4	20.5	50
SFP6285205007356	75*50	74.2	81	31	49.4	23.5	40
SFP6285205007357	75*63	74.2	82	31	62.5	27.5	40
SFP6285205007357.1	90*25	89.2	83	35.5	24.5	16	24
SFP6285205007358	90*32	89.2	84	35.5	31.5	18	24
SFP6285205007359	90*40	89.2	85	35.5	39.4	20.5	24
SFP6285205007360	90*50	89.2	86	35.5	49.4	23.5	24
SFP6285205007361	90*63	89.2	86	35.5	62.5	27.5	24
SFP6285205007362	90*75	89.2	86	35.5	74.2	31	20
SFP6285205007363	110*40	109.1	94	41.2	39.4	20.5	9
SFP6285205007364	110*50	109.1	102	41.2	49.4	23.5	9
SFP6285205007365	110*63	109.1	102	41.2	62.5	27.5	9
SFP6285205007366	110*75	109.1	103	41.2	74.2	31	9
SFP6285205007367	110*90	109.1	103	41.2	89.2	35.5	6

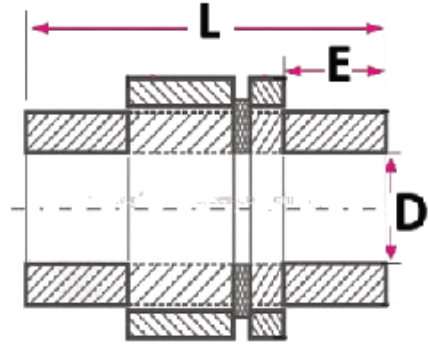

codes / الكود	size / مقياس	D	L	E	packing / PCS التعبئة / كرتون
SFP6285205004617	20	19.5	75	14.5	60
SFP6285205004624	25	24.5	80	16	40
SFP6285205004631	32	31.5	87	18	30
SFP6285205004648	40	39.4	93	20.5	20
SFP6285205004655	50	49.4	102	23.5	15
SFP6285205004662	63	62.5	112	27.5	10
SFP6285205004952	75	74.2	125	31	6
SFP6285205004969	90	89.2	138	35.5	2
SFP6285205004976	110	109.1	144	41.2	2

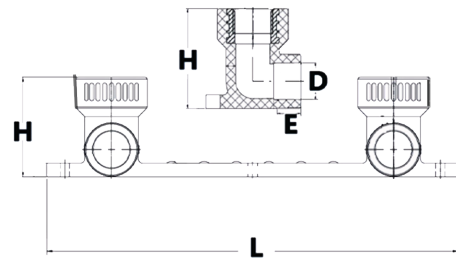

codes / الكود	size / مقياس	D	L	E	H	packing / PCS التعبئة / كرتون
SFP6285205007460	25*1/2	24.5	216.5	14.5	52.2	20
SFP6285205007595	25*3/4	24.5	216.5	14.5	56.3	20

ANTI UV BALL VALVE UNION

محبس سكين شد وصل مقاوم للأشعة

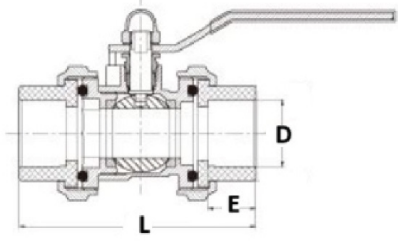

codes / الكود	size / مقاس	D	L	E	packing / PCS التعبئة / كرتون
SFP6285205007391.2	20	19.5	78	14.5	30
SFP6285205007392	25	24.5	86	16	30
SFP6285205007393	32	31.5	102	18	15
SFP6285205007394	40	39.4	117	20.5	15
SFP6285205007395	50	49.4	146	23.5	10
SFP6285205007396	63	62.5	165	27.5	6
SFP6285205007397	75	74.2	181	31	3
SFP6285205007398	90	89.2	207	35.5	2
SFP6285205007398.1	110	109.1	225	41.2	2

ANTI UV PPR GATE VALVE

محبس انجليزي مقاوم للأشعة

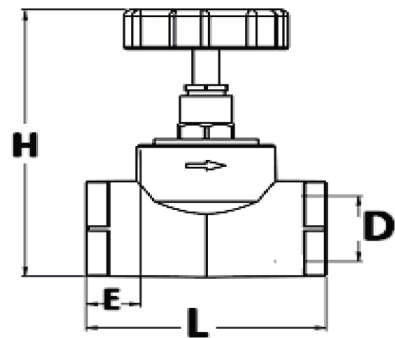

codes / الكود	size / مقاس	D	L	E	H	packing / PCS التعبئة / كرتون
SFP6285205007408	20	19.5	73	14.5	96	25
SFP6285205007409	25	24.5	73	16	105	20
SFP6285205007410	32	31.5	86	18	109	15
SFP6285205007411	40	39.4	93	20.5	129	10
SFP6285205007412	50	49.4	103	23.5	138	8
SFP6285205007413	63	62.5	114	27.5	152	6

ANTI UV Ball Valve

محبس سكين مقاوم الأشعة

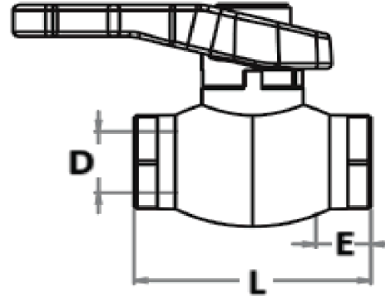

codes / الكود	size / مقاس	D	L	E	packing / PCS التعبئة / كرتون
SFP6285205007376	20	19.5	66	14.5	30
SFP6285205007377	25	24.5	73	16	30
SFP6285205007378	32	31.5	88	18	20
SFP6285205007379	40	39.4	105	20.5	10
SFP6285205007380	50	49.4	125	23.5	8
SFP6285205007381	63	62.5	150	27.5	4
SFP6285205007382	75	74.2	165	31	4

ANTI UV CONCEALED LONG VALVE

محبس كروم مطول مقاوم للأشعة

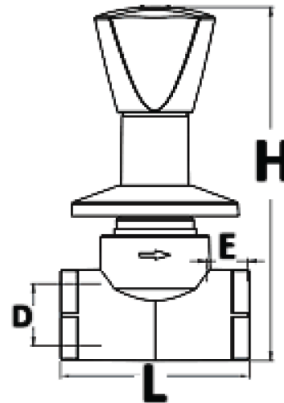

codes / الكود	size / مقاس	D	L	E	H	packing / PCS التعبئة / كرتون
SFP6285205007443	20*3/4	19.5	73	14.5	140	10
SFP6285205007445	25*3/4	24.5	73	16	140	10
SFP6285205007447	32*3/4	31.5	86	18	148	10
SFP6285205007449	32*1	31.5	86	18	148	10
SFP6285205007450	40	39.4	93	20.5	154	10
SFP6285205007452	50	49.4	103	23.5	163	8

ANTI UV CONCEALED LIGHT WEIGHT VALVE

محبس كروم وسط مقاوم للأشعة

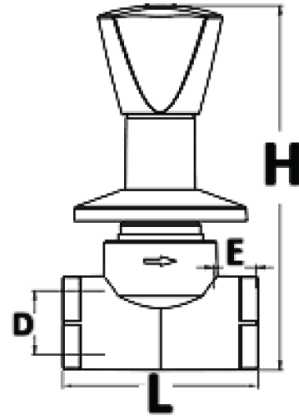

codes / الكود	size / مقاس	D	L	E	H	packing / PCS التعبئة / كرتون
SFP6285205007444	25*3/4	24.5	73	16	140	10
SFP6285205007446	32*1	31.5	86	18	148	10



ANTI UV GATE UNION VALVE

محبس انجليزي شد وصل مقاوم للأشعة

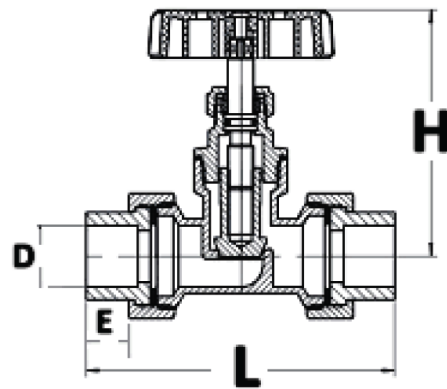

codes / الكود	size / مقاس	D	L	E	H	packing / PCS التعبئة / كرتون
SFP6285205007426	20	19.5	78	14.5	96	25
SFP6285205007427	25	24.5	86	16	105	20
SFP6285205007428	32	31.5	102	18	109	15
SFP6285205007429	40	39.4	117	20.5	129	10
SFP6285205007430	50	49.4	146	23.5	138	8
SFP6285205007431	63	62.5	168	27.5	152	6
SFP6285205007432	75	74.2	186	31	164	4
SFP6285205007433	90	89.2	215	35.5	188	2
SFP6285205007434	110	109.1	233	41.2	208	2

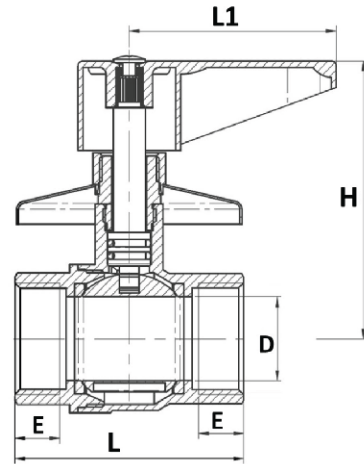
ANTI UV SIPHONE VALVE (MEDIUM/HEAVY) (وسط /ثقيل) محبس سيفون مقاوم للأشعة

codes / الكود	size / مقاس	D	L	L1	E	H	packing /PCS التعبئة / كرتون
SFP6285205007457.1	25	24.5	73	60	16	110	4
SFP6285205007457.2	25	24.5	73	60	16	110	4
SFP6285205007457.3	32	31.5	88	66	18	115	4
SFP6285205007457.4	32	31.5	88	66	18	115	4
SFP6285205007457.5	40	39.4	105	88	20.5	133	2
SFP6285205007457.6	50	49.4	125	91	23.5	138	2

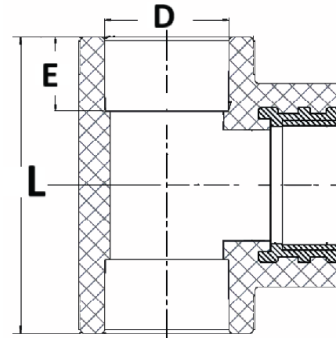
ANTI UV FEMALE BRASS TEE
قسام سن داخلي ذهبي مقاوم للأشعة

codes / الكود	size / مقاس	D	L	E	packing /PCS التعبئة / كرتون
SFP6285205007604	20 * 1/2	19.5	52	14.5	100
SFP6285205007605	20 * 3/4	19.5	52	14.5	75
SFP6285205007606-1	25 * 1/2	24.5	72	16	60
SFP6285205007607	25 * 3/4	24.5	72	16	60
SFP6285205007608	32 * 1/2	31.5	86	18	30
SFP6285205007609	32 * 3/4	31.5	86	18	30
SFP6285205007610	32 * 1	31.5	86	18	30

ANTI UV MALE BRASS TEE

قسام سن خارجي مقاوم للأشعة

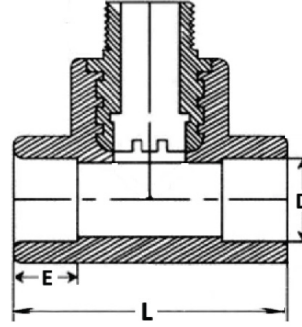
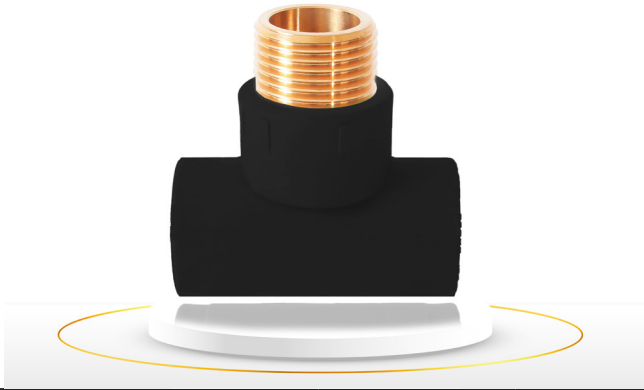

codes / الكود	size / مقاس	D	L	E	packing /PCS التعبئة / كرتون
SFP6285205007618	20 * 1/2	19.5	52	14.5	75
SFP6285205007619	20 * 3/4	19.5	52	14.5	75
SFP6285205007620	25 * 1/2	24.5	72	16	60
SFP6285205007621	25 * 3/4	24.5	72	16	60
SFP6285205007622	32 * 1/2	31.5	86	18	40
SFP6285205007623	32 * 3/4	31.5	86	18	20
SFP6285205007624	32 * 1	31.5	86	18	20



ANTI UV FEMALBRASS SOCKET

جلبة سن داخلي ذهبي مقاوم للأشعة

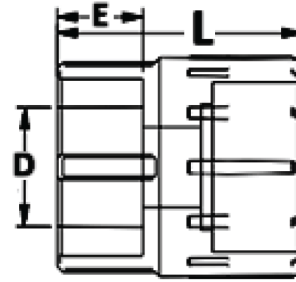

codes / الكود	size / مقاس	D	L	E	packing unit التعبئة
SFP6285205007647	20*1/2	19.5	38	14.5	120
SFP6285205007648	20*3/4	19.5	42	14.5	100
SFP6285205007649	25*1/2	24.5	43	16	120
SFP6285205007650	25*3/4	24.5	44	16	100
SFP6285205007651	32*1/2	31.5	46	18	50
SFP6285205007652	32*3/4	31.5	45	18	50
SFP6285205007653	32*1	31.5	48	18	50

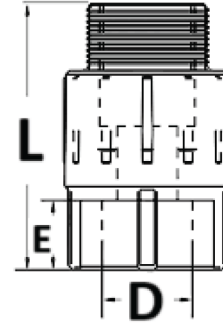
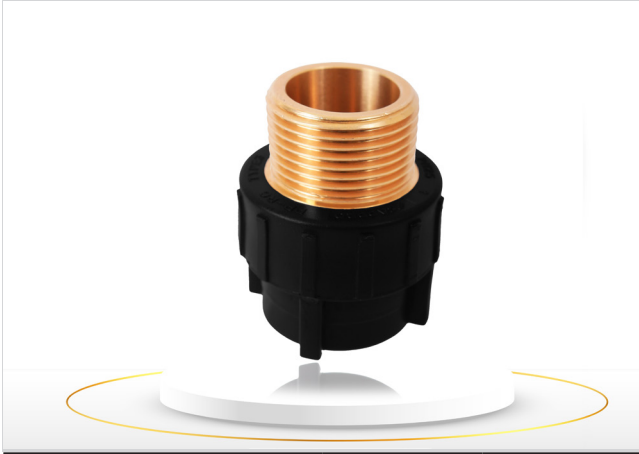
ANTI UV MALE BRASS SOCKET
جلبة سن خارجي ذهبي مقاوم للأشعة

codes / الكود	size / مقاس	D	L	E	packing /PCS التعبئة / كرتون
SFP6285205008001	20*1/2	19.5	45	14.5	120
SFP6285205008002	20*3/4	19.5	46	14.5	100
SFP6285205008003	25*1/2	24.5	47	16	120
SFP6285205008004	25*3/4	24.5	48	16	100
SFP6285205008005	32*1/2	31.5	48	18	40
SFP62852050080057	32*3/4	31.5	51	18	40
SFP6285205008006	32*1	31.5	54	18	30

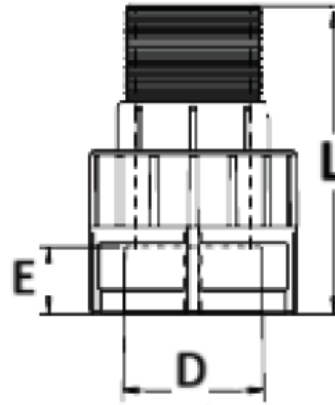
ANTI UV MALE HEX BRASS SOCKET
جلبة سن خارجي ذهبي سداسي مقاوم للأشعة

codes / الكود	size / مقاس	D	L	E	packing /PCS التعبئة / كرتون
SFP6285205008032	32*1	31.5	80	18	30
SFP6285205008034	40*1-1/4	39.4	81	20.5	20
SFP6285205008035	50*1-1/2	49.4	90	23.5	15
SFP6285205008036	63*2	62.5	95	27.5	10
SFP6285205008037	75*2-1/2	74.2	108	31	8
SFP6285205008038	90*3	89.2	140	35.5	4
SFP6285205008038.1	110*4	109.1	153	41.2	2

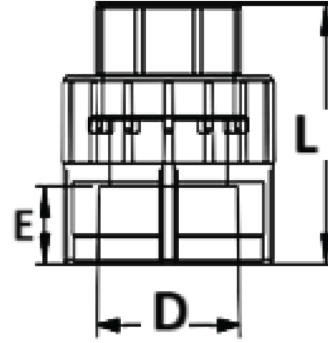
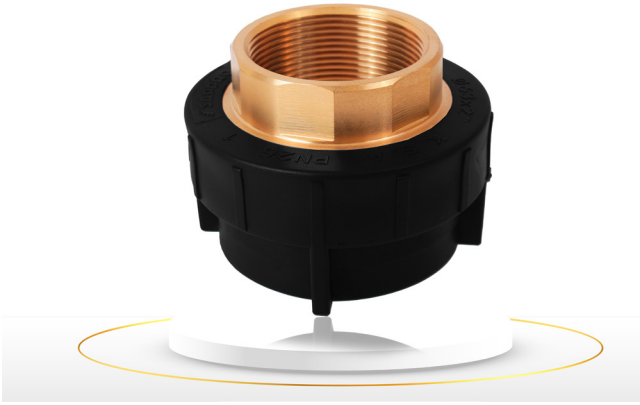

codes / الكود	size / مقاس	D	L	E	packing /PCS التعبئة / كرتون
SFP6285205008020	32*1	31.5	55	18	50
SFP6285205008021	40*1-1/4	39.4	65	20.5	15
SFP6285205008022	50*1-1/2	49.4	70	23.5	15
SFP6285205008023	63*2	62.5	75	27.5	10
SFP6285205008023.1	75*2-1/2	74.2	80	31	8
SFP6285205008024	90*3	89.2	105	35.5	4
SFP6285205008024.1	110*4	109.1	110	41.2	2

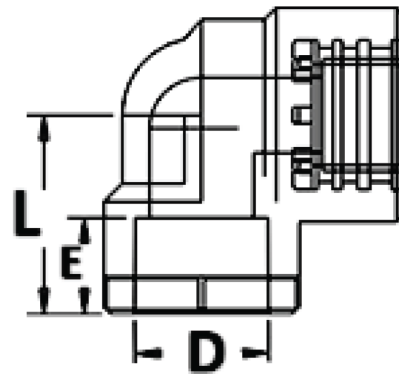

codes / الكود	size / مقاس	D	L	E	packing /PCS التعبئة / كرتون
SFP6285205008046	20 * 1/2	19.5	35	14.5	100
SFP6285205008047	20 * 3/4	19.5	35	14.5	100
SFP6285205008048	25 * 1/2	24.5	40	16	90
SFP6285205008049	25 * 3/4	24.5	40	16	75
SFP6285205008050	32 * 1/2	31.5	45	18	40
SFP6285205008051	32 * 3/4	31.5	45	18	40
SFP6285205008052	32 * 1	31.5	45	18	40

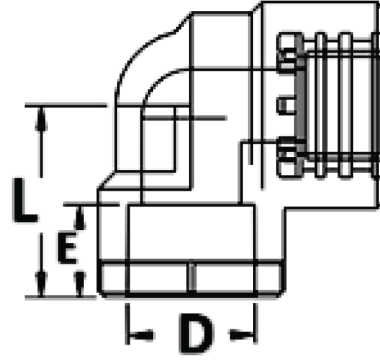

codes / الكود	size / مقاس	D	L	E	packing /PCS التعبئة / كرتون
SFP6285205008059	20 * 1/2	19.5	33	14.5	75
SFP6285205008060	20 * 3/4	19.5	34	14.5	75
SFP6285205008061	25 * 1/2	24.5	36	16	75
SFP6285205008062	25 * 3/4	24.5	36	16	60
SFP6285205008062.1	32 * 1/2	31.5	43	18	40
SFP6285205008063	32 * 3/4	31.5	43	18	40
SFP6285205008064	32 * 1	31.5	45	18	30

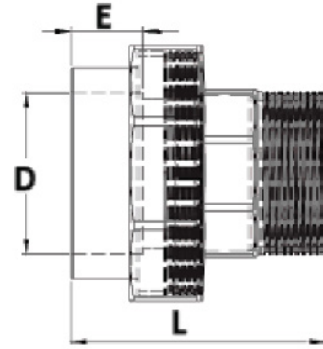
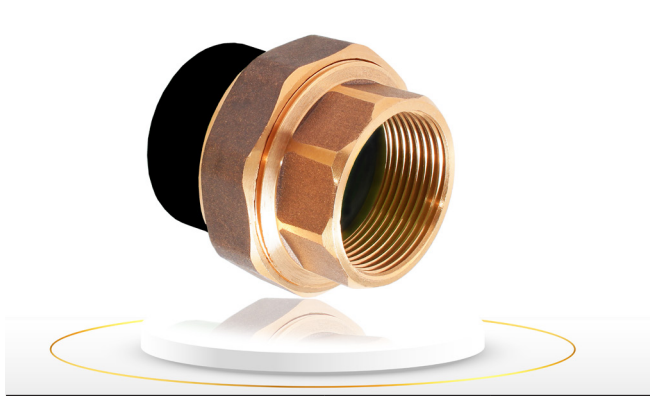

codes / الكود	size / مقاس	D	L	E	packing /PCS التعبئة / كرتون
SFP6285205008098	20*1/2	19.5	49	14.5	50
SFP6285205008099	25*3/4	24.5	58	16	40
SFP6285205008100	32* 3/4	31.5	68	18	30
SFP6285205008101	32*1	31.5	81	18	30
SFP6285205008102	40* 1-1/4	39.4	89	20.5	30
SFP6285205008103	50* 1-1/2	49.4	105	23.5	15
SFP6285205008104	63* 2	62.5	120	27.5	8
SFP6285205008105	75* 2-1/2	74.2	168	31	6
SFP6285205008105.1	90*3	89.2	178	35.5	6

ANTI UV TRANSITION MALE BRASS UNION

شد وصل سن خارجي مقاوم للأشعة

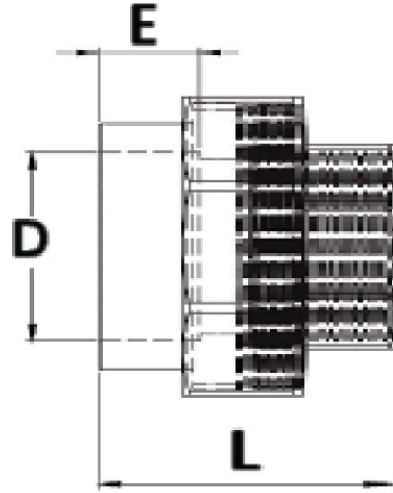
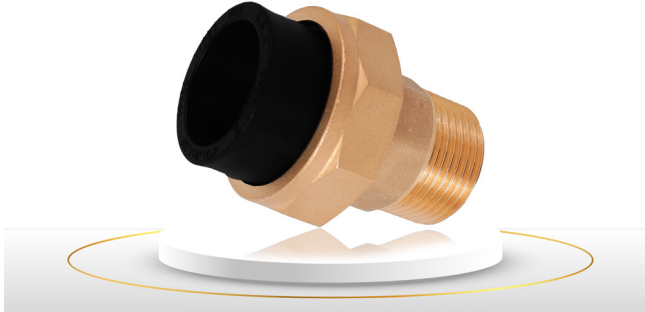

codes / الكود	size / مقاس	D	L	E	packing /PCS التعبئة / كرتون
SFP6285205008116	20*1/2	19.5	58	14.5	50
SFP6285205008117	25*3/4	24.5	65	16	40
SFP6285205008118	32*3/4	31.5	74	18	40
SFP6285205008119	32*1	31.5	87	18	30
SFP6285205008120	40*1-1/4	39.4	98	20.5	30
SFP6285205008121	50*1-1/2	49.4	112	23.5	20
SFP6285205008122	63*2	62.5	128	27.5	8
SFP6285205008123	75*2-1/2	74.2	178	31	6
SFP6285205008124	90*3	89.2	188	35.5	4

CONCEALED VALVE ACCESSORIES

ديكور محبس كروم

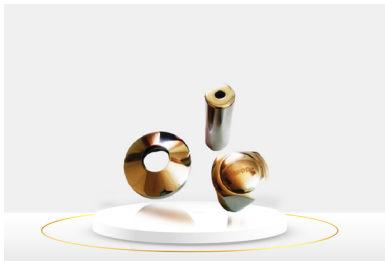

codes / الكود	size / مقاس	packing /PCS التعبئة / كرتون
SFP6285205008155	25	15

SIPHONE VALVE ACCESSORIES

ديكور محبس سيفون

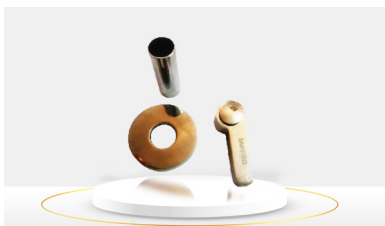

codes / الكود	size / مقاس	packing /PCS التعبئة / كرتون
SFP6285205003307	32	15

CONCEALED VALVE BRASS MECHANISM
قلب محبس كروم

codes / الكود	size / مقاس	packing /PCS التعبئة / كرتون
SFP6285205008138	25	75
SFP6285205008139	32	60
SFP6285205008140	40	50

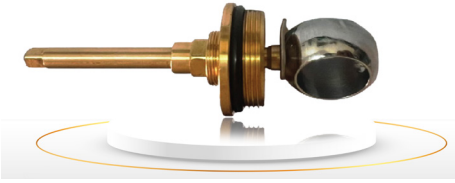
SIPHONE VALVE BRASS MECHANISM
قلب محبس سيفون

codes / الكود	size / مقاس	packing /PCS التعبئة / كرتون
SFP6285205008162	32	50

GATE VALVE BRASS MECHANISM
قلب محبس انجليزي

codes / الكود	size / مقاس	packing /PCS التعبئة / كرتون
SFP6285205008141	25	30
SFP6285205008142	32	20
SFP6285205008143	40	15
SFP6285205008144	50	15
SFP6285205008145	63	10

CONCEALED VALVE EXTENSION BRASS
تطويلة محبس كروم

codes / الكود	size / مقاس	packing /PCS التعبئة / كرتون
SFP6285205008162	25	150

PPR WELDING SOCKET

لقم لحام مواسير بولي بروبيلين



codes / الكود	size / مقاس	packing / PCS التعبئة / كرتون
SFP6285205008125	20	50
SFP6285205008126	25	50
SFP6285205008127	32	40
SFP6285205008128	40	30
SFP6285205008129	50	20
SFP6285205008130	63	15
SFP6285205008131	75	10
SFP6285205008132	90	8
SFP6285205008133	110	8

PPR PIPE REPAIR KIT

وصلة اصلاح مواسير



codes / الكود	size / مقاس	packing / PCS التعبئة / كرتون
SFP6285205008163	7	50
SFP6285205008164	9	50
SFP6285205008165	11	50

PPR PIPE CUTTER

مقص قطع مواسير بولي بروبيلين



codes / الكود	size / مقاس	packing / PCS التعبئة / كرتون
SFP6285205008134	20-40	50

PPR PIPE CUTTER
مقص قطع مواسير بولي بروبلين

codes / الكود	size / مقاس	packing / PCS التعبئة / كرتون
SFP6285205008135	50-110	10

PPR PIPE PRESSURE TESTING MACHINE
ماكينة اختبار ضغط مواسير

codes / الكود	size / مقاس	packing / PCS التعبئة / كرتون
SFP6285205008166	20-110	4

PPR SOCKET FUSION WELDING MACHINE
ماكينة لحام مواسير بولي بروبلين

codes / الكود	size / مقاس	packing / PCS التعبئة / كرتون
SFP6285205008136	20-63	4

PPR SOCKET FUSION WELDING MACHINE
ماكينة لحام مواسير بولي بروبلين

codes / الكود	size / مقاس	packing / PCS التعبئة / كرتون
SFP6285205008137	75-110	4

مسؤولية الإدارة وسياسة الجودة

في سابرو نحن ملتزمون بما يلي:

تقييم جودة المواد الخام والسلع شبه المصنعة والمنتجات النهائية خلال عملية الإنتاج

ضمان أن تعمل عملية الإنتاج بالكامل وفقاً للمعايير المطلوبة، وفي حال حدوث أي

انحرافات، يتم اتخاذ الإجراءات التصحيحية اللازمة.

اقتراح تدابير وخطط لتحسين مستوى السلع المنتجة دون زيادة كبيرة في التكلفة









تطوير الوعي بالجودة بين الأقسام المختلفة في وحدتنا الصناعية

تقديم منتجات ذات جودة ممتازة تتوافق مع متطلبات وتوقعات عملائنا

تنفيذ وصيانة نظام إدارة جودة فعال

الالتزام بمعدلات إنتاج عالية وبجودة عالية وضمان تسليم المنتجات في الوقت المحدد

خصائص أنابيب سابرو

<p>المرونة تتميز بمرونة عالية تجعلها سهلة التثبيت والتكيف مع الظروف المختلفة.</p>	 <p>01</p>	<p>02</p>	<p>سهولة التركيب سهولة التركيب وتوفير الوقت والجهد في عملية التثبيت.</p> 
<p>القوة الميكانيكية تمتاز بقوة ميكانيكية عالية تضمن ملائمتها وطول عمرها.</p>	 <p>03</p>	<p>04</p>	<p>مقاومة التآكل تقاوم التآكل الكيميائي وتضمن أداء ممتازاً في البيئة القاسية.</p> 
<p>مقاومة الصدمات مصممة لتحمل الصدمات والضغط العالية.</p>	 <p>05</p>	<p>06</p>	<p>مقاومة الهجمات البيولوجية تقاوم نمو البكتيري والفطريات.</p> 
<p>مقاومة الحريق مصنوعة بمواد مقاومة للحريق لضمان السلامة.</p>	 <p>07</p>	<p>08</p>	<p>مقاومة التآكل تضمن الأداء الممتاز على المدى الطويل دون تدهور.</p> 

تمتلك أنابيب **سابرو** قسم خدمة فنية مجهز تجهيزاً جيداً يضم مهندسين مؤهلين لتقديم المشورة الفنية للمهندسين المدنيين والمقاولين وغيرهم، بشأن منتجاتها من UPVC و PPR و تطبيقاتها.

الرؤية

أن نكون الرواد في صناعة المنتجات البلاستيكية على مستوى المملكة العربية السعودية والشرق الأوسط، مع تحقيق أعلى معايير الابتكار والجودة، وبناء مستقبل مستدام يدعم التطور الصناعي ويعزز مكانة المملكة في الأسواق العالمية

الرسالة

الجودة أولاً: التزامنا بتقديم منتجات بلاستيكية بمعايير عالمية تلبى تطلعات عملائنا وتساهم في تحقيق نجاحاتهم
الابتكار المستدام: السعي المستمر لتطوير تقنيات إنتاج متقدمة تجمع بين الكفاءة والوعي البيئي.
رضا العملاء: بناء علاقات طويلة الأمد مع عملائنا، قائمة على الثقة والاحترام المتبادل.
التطور الصناعي: دعم عجلة التنمية الوطنية من خلال تقديم حلول بلاستيكية تواكب احتياجات السوق المحلي والعالمي.
المسؤولية المجتمعية: تعزيز الاستدامة وحماية البيئة عبر استخدام مواد صديقة للبيئة وتقليل الأثر البيئي.

قيمنا الأساسية

التفوق: نسعى دائماً لتجاوز التوقعات وتحقيق أعلى معايير الجودة.
الشراكة: نؤمن بأهمية التعاون المشترك لتحقيق النجاح المتبادل.
الشفافية: التزامنا بالوضوح والصراحة في جميع تعاملاتنا.
التطوير المستمر: الاستثمار في التكنولوجيا وتدريب الكوادر لتحقيق التميز.

رحلة من الجودة والإبداع

مصنع السعودية للمنتجات البلاستيكية ليس مجرد مصنع، بل هو رمز للابتكار والتميز في عالم الصناعة. تأسسنا برؤية واضحة تهدف إلى تقديم حلول بلاستيكية متطورة تلبي احتياجات القطاعات المختلفة في المملكة العربية السعودية وخارجها.

أصبحنا الشريك الموثوق لعدد لا يحصى من الشركات والمؤسسات، بفضل التزامنا بمعايير الجودة العالمية والتطور المستمر. نحن نستخدم أحدث التقنيات لضمان أن كل منتج نطرحه يمثل الجودة التي يستحقها.

منتجاتنا مصممة لتدوم

نحن لا نضع فقط المنتجات، بل نضع الثقة. منتجاتنا البلاستيكية تتميز بالكفاءة العالية، والمتانة الفائقة، والتصميم الذي يتناسب مع كافة المتطلبات. سواء كنت تبحث عن حلول للبنية التحتية، أو الأنظمة الحرارية، أو المشاريع الضخمة، نحن هنا لتقديم الأفضل دائمًا.

هدفنا: رضاكم

بفضل فريقنا المحترف وشففنا بالتميز، نجعل كل مشروع لكم نجاحًا مستدامًا. لأننا نؤمن بأن الجودة ليست مجرد خيار، بل هي أسلوب حياة.

من أجلكم صنعناه

سابرو

أنابيب و ملحقاتها



تقنية
الألمانية

صناعة
سعودية

خيارك الذكي

تتميز منتجات سابرو بأعلى معايير الجودة والأداء مما جعلها الخيار الأفضل.



صنع من أجلكم

+966112469000 / +966505248483

sales@sfpp.com.sa

www.sfpp.com.sa

شركة مصنع السعودية للمنتجات البلاستيكية
المملكة العربية السعودية - الرياض
ص.ب: 225931 - الرمز البريدي: 11324

